



**PACIFIC  
OCEAN  
LITTER  
PROJECT**

## **Feasibility Study of Technologies to Process Plastics Waste-to-Commodities**



**SPREP**  
Secretariat of the Pacific Regional  
Environment Programme

© Secretariat of the Pacific Regional Environment Programme (SPREP) 2024

Reproduction for educational or other non-commercial purposes is authorised without prior written permission from the copyright holder and provided that SPREP and the source document are properly acknowledged. Reproduction of this publication for resale or other commercial purposes is prohibited without prior written consent of the copyright owner.

**Feasibility study of technologies to process plastic  
waste-to-commodities.**

Apia, Samoa :  
SPREP, 2024.

104 p. 29 cm.

ISBN: 978-982-04-1365-8 (print)  
978-982-04-1366-5 (ecopy)

1. Recycling (Waste, etc.) – Technological innovations  
– Oceania. 2. Waste management – Refuse and refuse  
Disposal – Oceania. 3. Waste minimization – Cost  
effectiveness – Oceania. I. Pacific Regional  
Environment Programme (SPREP). II. Title.

363.728 20961

This study was commissioned by the Pacific Ocean Litter Project and  
conducted by Natural Capital Economics Pty Ltd.



Secretariat of the Pacific Regional Environment Programme (SPREP)

PO Box 240, Apia, Samoa, [sprep@sprep.org](mailto:sprep@sprep.org), [www.sprep.org](http://www.sprep.org)

SPREP's vision: The Pacific environment, sustaining our livelihoods and natural heritage in harmony with our cultures.



# Feasibility Study of Technologies to Process Plastics Waste-to-Commodities



**PACIFIC  
OCEAN  
LITTER  
PROJECT**



**SPREP**  
Secretariat of the Pacific Regional  
Environment Programme



# TABLE OF CONTENTS

1	<i>Introduction</i> .....	1
1.1	Background.....	1
1.2	Purpose.....	2
1.3	Scope.....	2
2	<i>Literature Review to Identify Suitable Technologies</i> .....	3
2.1	Approach.....	3
2.2	Composition of Plastic Waste in PICs.....	3
2.3	Plastics Recycling Value Chain.....	10
2.4	Mechanical and Chemical Treatment and Energy Recovery.....	11
2.5	Capital and Operational Requirements.....	18
3	<i>Technologies</i> .....	19
3.1	Stage 1: Plastic Feedstock Preparation Stage.....	19
3.2	Stage 2: Plastic Moulding Techniques (Product Development).....	28
3.3	Remanufactured Commodities.....	38
3.4	Challenges to Plastics Recycling.....	47
4	<i>Stakeholder Engagement</i> .....	48
4.1	Stakeholder Engagement.....	48
4.2	Specific GEDSI Considerations.....	52
5	<i>Value Analysis of Potential Technologies to Remanufacturing Plastics</i> .....	54
5.1	Summary of MCA Results.....	54
5.2	Multi Criteria Analysis.....	55
5.3	Cost-Benefit Analysis.....	56
6	<i>Conclusion</i> .....	62
7	<i>Recommendations</i> .....	65
	<i>References</i> .....	69
	<i>Appendices</i> .....	72
A	<i>Stakeholder engagement</i> .....	72
B	<i>Multi Criteria Analysis</i> .....	89

## TABLES

Table 1 Common Plastic Profiles .....	4
Table 2. Description of plastic waste in PICs.....	6
Table 3 Estimated Plastic Waste Generation in Tonnes per Year .....	7
Table 4 Comparison of Plastic Properties .....	8
Table 5 Terminology used in different types of plastics recycling and recovery (Hopewell et al., 2009).....	11
Table 6 Mechanical and Chemical comparison (Ehsan et al, 2023; Vollmer et al., 2020).....	13
Table 7 Key differences between granulator and shredder machines. ....	20
Table 8 Shredder characteristics.....	21
Table 9 Shredder shaft types for soft or rigid plastics (Lau, 2023).....	21
Table 10 Granulator characteristics .....	22
Table 11 Sink-Float Separation Tank characteristics. ....	24
Table 12 Friction Washer characteristics. ....	25
Table 13 Mechanical Dryer characteristics.....	26
Table 14 Thermal Dryer characteristics .....	27
Table 15 Pelletiser characteristics.....	28
Table 16 Extrusion moulding characteristics .....	29
Table 17 Common Extruder types.....	29
Table 18 Injection moulding characteristics.....	31
Table 19 Four common types of injection moulding processes.....	31
Table 20 Blow moulding characteristics. ....	33
Table 21 Common blow moulding techniques.....	33
Table 22 Vacuum moulding characteristics.....	35
Table 23 Common vacuum forming techniques.....	36
Table 24 Machine Costs .....	41
Table 25 Planned stages for business plan .....	42
Table 26 Precious Plastic Machine Costs.....	43
Table 27 Legend for MCA.....	54
Table 28 Priority Technology for PIC context.....	54
Table 29. Multi Criteria Analysis Results .....	55
Table 30. Similarities and differences across the different options .....	57
Table 31. CBA inputs and assumptions.....	57
Table 32. Estimates of the NPVs and BCRs.....	59
Table 33 PIC recommended technology choices.....	62
Table 34 Pacific Island Stakeholder List .....	78
Table 35 Regional CSOs .....	82

Table 36 Stakeholder Analysis .....	84
Table 37 Stakeholder Interest and Concerns.....	85
Table 38: Even-Weighting Assignment for Objectives and Criteria.....	91
Table 39 Criteria and Measures.....	92
Table 40 Measures and assessment scoring sheet.....	93

## FIGURES

Figure 1. Plastics recycling value chain .....	10
Figure 2 Routes for dealing with plastic (Niessner and Norbert, 2022).....	11
Figure 3 Recycling technologies and their environmental impact (Deloitte, 2021).....	12
Figure 4 Simplified Circular Economy (ADB, 2020).....	17
Figure 5 Twin shaft shredder.....	20
Figure 6 Granulator .....	22
Figure 7 Continuous float-sink separator .....	24
Figure 8 Friction Washer .....	26
Figure 9 Simple Pelletiser Machine.....	27
Figure 10 Horizontal Extrusion Moulding .....	28
Figure 11 Injection Moulding.....	30
Figure 12 Blow Moulding .....	32
Figure 13 Four Vacuum (thermoforming) moulding techniques.....	34
Figure 14. BCRs for all three options.....	59
Figure 15. Cumulative cash flow for the three options.....	60
Figure 16. Contribution to variance (Option 2a) .....	61
Figure 17 MCA Formation Process .....	90
Figure 18 Logical process of the proposed MCA approach with multiple objectives.....	91

# 1 Introduction

As populations and economies grow across Pacific Island countries (PICs),<sup>1</sup> so does the use of plastics and the scale of the challenge to manage plastic waste. Single-use plastics, typical for packaging (e.g., plastic bags, PET bottles, polystyrene, and plastic film) are a major problem as lack of recycling options, poor waste disposal and/or management and chronic littering mean such plastic enters the environment and often into marine environments. This creates unacceptable environmental, public health and economic risks.

The Pacific Ocean Litter Project (POLP) seeks to eventually phase out single use plastics, but also to increase the reuse and recycling of single-use plastics. The single-use plastics targeted by POLP are generated from households and the tourism sector e.g., PET bottles, plastic bags, polystyrene take-away containers, and plastic straws.

## 1.1 Background

PICs face a significant challenge stemming from the widespread use of single-use plastics. SPREP (2020A) estimates that the annual generation of plastic waste to be up to 310,000 tonnes and this primarily originates from household litter and activities related to tourism. The accessibility and prevalence of single-use plastics have led to their extensive utilisation across diverse sectors, resulting in a substantial waste output within the region.

The extensive usage of single-use plastics has inflicted substantial harm on both the environment and societies within PICs. Plastic pollution has detrimentally impacted pristine coastal environments, marine ecosystems, and terrestrial landscapes. This form of pollution poses a direct threat to marine life through ingestion and entanglement, disrupts ecosystems, and contaminates vital water sources. Additionally, plastic waste exacerbates issues related to flooding and drainage, impeding communities' resilience to natural calamities.

On a societal level, plastic pollution adversely affects public health, tourism, and cultural heritage. The accumulation of plastic debris diminishes the visual appeal of natural landscapes, reduces tourism-generated revenue, and undermines traditional practices and livelihoods of local communities reliant on natural resources.

The trajectory of single-use plastics in PICs indicates a concerning pattern of exponential growth. With escalating urbanisation, population expansion, and increased consumerism, the demand for single-use plastics is poised to rise significantly in the foreseeable future.

Notwithstanding the challenges associated with plastic pollution, there exists economic opportunity in plastic recovery and recycling initiatives. Embracing the principles of the circular economy underscores the economic value inherent in recycling plastics, thereby transforming waste into a valuable resource. Through the adoption of efficient waste management systems and investment in recycling technologies, PICs stand to realise

---

<sup>1</sup> PICs refer to Cook Islands, Federated States of Micronesia, Fiji, Kiribati, Marshall Islands, Nauru, Niue, Palau, Papua New Guinea, Samoa, Solomon Islands, Tonga, Tuvalu, and Vanuatu



economic benefits such as job creation, resource reclamation, and reduced environmental costs linked to plastic pollution.

## 1.2 Purpose

The project aims to achieve the following objectives:

Identifying and evaluating technologies that are suitable for processing plastic waste into commodities, specifically tailored for micro-to-small social enterprise organisations operating within Pacific Island countries. The focus will be on technologies that are scalable, cost-effective, and environmentally sustainable, enabling these organisations to contribute effectively to waste management efforts.

Review and analyse the suitability of technology for processing plastic waste to commodities, considering various factors such as technological feasibility, supply chain dynamics, market demand for recycled commodities, and sustainability considerations. This analysis will provide insights into the operational viability and potential impact of these technologies within the Pacific Island context, guiding decision-making processes for adoption and implementation.

Consult with key stakeholders, including government entities, industry representatives, community leaders, and environmental organisations, to gather input and insights on waste generation patterns, existing collection systems, processing capabilities, and stakeholder engagement strategies.

Develop case studies that showcase best practices, successful interventions, and innovative approaches in plastic waste management for Pacific Island countries. These case studies will serve as starting points to inform future initiatives aimed at addressing plastic pollution challenges effectively.

## 1.3 Scope

The OECD defines **micro** enterprises as having 1 to 9 employees and **small** enterprises as having 10 to 49 employees.<sup>2</sup>

Consequently, the technologies that are considered for analysis in this project will be evaluated with this constraint in mind. As a result, larger scale technologies that are effective at transforming plastics to commodities may be eliminated from a more in-depth consideration. These technologies will be identified and recommended for future exploration.

---

<sup>2</sup> [https://data.oecd.org/entrepreneur/employees-by-business-size.htm#:~:text=For%20this%20indicator%2C%20enterprises%20are,persons%20employed%20\(large%20enterprises\).](https://data.oecd.org/entrepreneur/employees-by-business-size.htm#:~:text=For%20this%20indicator%2C%20enterprises%20are,persons%20employed%20(large%20enterprises).)

## **2 Literature Review to Identify Suitable Technologies**

### **2.1 Approach**



A web search was conducted to identify relevant literature, case studies, technical guides, and policy insights targeting solutions applicable to micro-to-small businesses and environmental technologies. The strategy included the use of keywords and search strings specific to plastic waste management, recycling technologies, micro-to-small businesses, and Pacific Island countries.

Relevant databases and sources were selected to research on technologies applicable for smaller enterprises in plastics waste management. These sources drew from the SPREP database, industry white papers, government resources, academic research, and previous reports on this subject matter.

### **2.2 Composition of Plastic Waste in PICs**





The ASTM International Resin Identification Coding System guides the categorisation of plastic materials for recycling, aiming to easily identify the exact plastic resin used in a product. This system, along with details on chemical structures, resin traits, and typical uses, has been gathered and outlined in a Table 1.

**Table 1 Common Plastic Profiles<sup>3</sup>**

Polymer Name	Resin No.	Type <sup>4</sup>	Properties	Typical Uses	Products made from Recycled Content	Recyclability
<b>Polyethylene terephthalate</b>	 <b>PETE</b>	Thermoplastic	<ul style="list-style-type: none"> <li>• Clear and optically smooth surfaces for oriented films</li> <li>• Excellent barrier for O<sub>2</sub>, H<sub>2</sub>O and CO<sub>2</sub></li> <li>• High impact capability and shatter resistance</li> <li>• Excellent resistance to most solvents</li> <li>• Hot-filling capability</li> </ul>	Bottles and flasks for soft drinks, mineral water, detergents and pharmaceutical products; blister packs; packaging for ready meals.	<ul style="list-style-type: none"> <li>• Fibre for carpet, fleece jackets, comforter fill and tote bags</li> <li>• Containers for food, beverages (bottles) and non-food items</li> <li>• Films and sheets · Strapping</li> </ul>	PET is one of the most easily recycled plastics
<b>High-density polyethylene</b>	 <b>HDPE</b>	Thermoplastic	<ul style="list-style-type: none"> <li>• Excellent resistance to most solvents</li> <li>• Higher tensile strength compared to other PE forms.</li> <li>• Relatively stiff material with useful temperature capabilities</li> </ul>	Thick-walled applications such as bottles and flasks, barrels, jerry cans, crates and jalls; films for refuse bags; packaging for carpets and instruments	<ul style="list-style-type: none"> <li>• Bottles for non-food items such as personal care and household cleaners</li> <li>• Plastic lumber for outdoor decking, fencing and picnic tables.</li> <li>• Pipe, floor tiles, buckets, crates, flow pots, garden edging, film and sheet, and recycling bins</li> </ul>	HDPE is easily recycled.
<b>Polyvinyl chloride</b>	 <b>V</b>	Thermoplastic	<ul style="list-style-type: none"> <li>• High impact strength, clarity and processing performance</li> <li>• Resistant to grease, oil and chemicals</li> </ul>	Blister and press-through packs for medication; films for perishables; Refillable milk bottles; specific refillable packaging for liquids	<ul style="list-style-type: none"> <li>• Windows, pipes, decking, fencing, panelling, gutters, carpet backing, floor tiles and mats, resilient flooring, mud flaps, cassette trays, electrical boxes, cables, traffic cones, garden hose and mobile home skirting.</li> <li>• Packing, film and sheet and loose-leaf binders</li> </ul>	PVC is one of the least recyclable plastic due to additives. Potentially harmful substances are also created by its disposal.





<sup>3</sup> Shen and Worrell, 2014; Sea Studios Foundation, n.d.; Locock, 2017

<sup>4</sup> Thermoplastic or Thermoset

Polymer Name	Resin No.	Type <sup>4</sup>	Properties	Typical Uses	Products made from Recycled Content	Recyclability
<b>Low-density polyethylene</b>	 LDPE	Thermoplastic	<ul style="list-style-type: none"> <li>• Excellent resistance to acids, bases and vegetable oils</li> <li>• Toughness, flexibility and relative transparency</li> <li>• Good for packaging that requires heat sealing</li> </ul>	Foil and film, such as shrink wraps, tubular film, sacks and covering wraps for bread, vegetables, fruit and carrier bags; Ultra-thin films: elastic wrap foil or stretch films	<ul style="list-style-type: none"> <li>• Shipping envelopes, garbage bin liners, floor tile, panelling, furniture, film and sheet, compost bins, garbage bins, landscape timber and outdoor lumber</li> </ul>	LDPE is not usually recycled.
<b>Polypropylene</b>	 PP	Thermoplastic	<ul style="list-style-type: none"> <li>• Excellent optical clarity in biaxially oriented films and stretch blow moulded containers.</li> <li>• Low moisture vapour transmission</li> <li>• Inertness towards acids, alkalis and most solvents</li> </ul>	Buckets, crates, boxes, caps for bottles or flasks, transparent packaging for flowers, plants, confection products; yogurt and dairy product cups; industrial adhesive tapes	<ul style="list-style-type: none"> <li>• Automobile applications such as battery cases, signal lights, battery cables, brooms and brushes, ice scrapers, oil funnels, and bicycle racks</li> <li>• Garden rakes, storage bins, shipping pallets, sheeting, trays</li> </ul>	PP is not easily recycled. Differences in the varieties of type and grade, mean achieving consistent quality during recycling is difficult.
<b>Polystyrene</b>	 PS	Thermoplastic	<ul style="list-style-type: none"> <li>• Excellent moisture barrier for short shelf life products</li> <li>• Excellent optical clarity in general purpose form</li> <li>• Significant stiffness in both foamed and rigid forms</li> <li>• Low density and high stiffness in foamed applications</li> <li>• Low thermal conductivity and excellent insulation properties in foamed form</li> </ul>	Food service disposables; boxes and dishes for meat products and vegetables; boxes for ice; boxes for video tapes; Buffer packaging for household devices, electronics and instruments; flasks and pipettes for the medical industry; egg packaging and fast food packaging	<ul style="list-style-type: none"> <li>• Thermal insulation, thermometers, light switch panes, vents, desk trays, rulers and license plate frames</li> <li>• Cameras or video cassette casings</li> <li>• Foamed foodservice applications such as eggshell cartons.</li> <li>• Plastic moulding (i.e. wood replacement products</li> <li>• Expandable polystyrene (EPS) foam protective packaging</li> </ul>	Recycling PS is possible, but not normally economically viable.
<b>Other*</b>	 Other	Either	Dependent on resin combination	Simple to complex applications	Bottles and plastic lumber applications	Mixed resin plastics like #7 are difficult, if not impossible, to recycle.

A summary of the four priority waste categories for the POLP and their recycling potential is summarised in the Table 2 from SPREP (2020a).

**Table 2. Description of plastic waste in PICs**

Plastic waste	Abbreviation	Resin identification code	Waste-to-commodity recycling potential	Ease of recycling (Easy, Moderate, Hard)
<b>Water bottles</b> 	Polyethylene Terephthalate (PET)	1	Fleece garments, carpets, furniture, plastic bottles	Easy
<b>Plastic bags</b> 	Low-density Polyethylene (LDPE)	4	Trash cans, floor tiles	Hard
<b>Polystyrene take-away containers</b> 	Polystyrene (PS)	6	Rigid foam insulation, egg cartons, picture frames, home decoration, foam protective packaging	Hard
<b>Plastic straws</b> 	Polypropylene (PP)	5	Brooms, shovels, watering cans, mixing bowls, cutting boards, storage bins	Hard

Source: SPREP (2020A).

High-quality recycled material can be made from containers made from HDPE, PP and PET (especially bottles). Films are hard to sort, and the large use of plasticisers and other additives makes it difficult to guarantee a high purity of the recycled material. Hence, this material is instead typically used to replace other materials rather than plastics when it is recycled (e.g. in construction) (Shen and Worrell, 2014).

## Pacific Plastic Profile

The table below (Table 3) presents data on the estimated plastic waste generation in tonnes per year for all 14 PICs. This data is important for understanding the scale and distribution of plastic waste generation across the Pacific.

**Table 3 Estimated Plastic Waste Generation in Tonnes per Year<sup>5</sup>**

Country	PET	HDPE	PVC	LDPE	PP	PS	Other
<b>PWFI Ratio</b>	<b>20.7%</b>	<b>12%</b>	<b>0.3%</b>	<b>14.1%</b>	<b>7.7%</b>	<b>18.5%</b>	<b>26.7%</b>
COK	174	101	3	119	65	156	224
FJI	5,024	2,912	73	3,422	1,869	4,490	6,480
FSM	581	337	8	396	216	519	749
KIR	519	301	8	354	193	464	669
MHL	311	180	5	212	116	278	401
NRU	83	48	1	57	31	74	107
NIU	25	14	0	17	9	22	32
PLW	163	94	2	111	61	146	210
PNG	42,518	24,648	616	28,962	15,816	37,999	54,842
WSM	1,039	602	15	708	386	929	1,340
SLB	3,135	1,817	45	2,135	1,166	2,802	4,044
TON	575	333	8	392	214	514	742
TUV	62	36	1	42	23	55	80
VUT	1,472	853	21	1,003	548	1,316	1,899
<b>Grand Total</b>	<b>55,683</b>	<b>32,279</b>	<b>807</b>	<b>37,928</b>	<b>20,712</b>	<b>49,763</b>	<b>71,820</b>

Based on the estimated plastic waste generation data, it is clear that PET (Polyethylene Terephthalate), PS (Polystyrene), and miscellaneous "Other" are the waste fractions with the highest volumes. PET, commonly found in beverage bottles and food containers, makes up a significant portion of plastic waste generated, particularly in Papua New Guinea (42,518 tonnes) and Fiji (5,024 tonnes). PS (Polystyrene), used in disposable items like coffee cups and food packaging, also shows high waste volumes, with 37,999 tonnes in Papua New Guinea and 4,490 tonnes in Fiji. The "Other" plastics category, despite representing the largest volume (71,820 tonnes total), is a catch all category for all other plastic types not identified in the previous 6 waste streams. It is particularly challenging to recycle due to its mixed nature of materials it and poses considerable waste management challenges beyond the average capacity of recycling in the Pacific. Thus "Other" will not be considered a priority waste stream due to the great difficulty in recycling.

LDPE (Low-Density Polyethylene) and HDPE (High-Density Polyethylene) have a moderate priority. LDPE, prevalent in plastic bags, soft packaging and pallet wrap, makes up a significant portion of plastic waste generated in Papua New Guinea (28,962 tonnes) and Fiji (3,422 tonnes). HDPE, used in products like milk jugs and detergent bottles, likewise also contributes significantly to plastic waste volumes, with 24,648 tonnes in Papua New Guinea and 2,912 tonnes in Fiji. PP (Polypropylene), found in food containers and automotive parts, warrants attention due to notable waste volumes in some countries.

In contrast, PVC (Polyvinyl Chloride) can be deprioritised due to its relatively low waste generation across all countries (807 tonnes total). While PVC should not be entirely ignored, it poses less of an immediate challenge

<sup>5</sup> PRIF 2022 modified using IUCN 2021 plastic ratios from household waste.

compared to the other types of plastics and is the focus of world-wide bans in packaging. Based on quantities present and recycling potential the report team considers the focus of waste management and recycling efforts should prioritise on PET, PS, LDPE, HDPE and PP plastics to provide the most significant impact in reducing plastic waste and mitigating its environmental effects through recycling.

This analysis aligns with the POLP priority waste categories summarised in the Table 1 from SPREP (2020a) with the addition of HDPE.

## Thermoplastic, Thermoset, and Elastomeric Materials

Not all plastics are created equal. Understanding the fundamental differences between thermoplastics, thermosets, and elastomers is crucial for engineers, designers, manufacturers, and recyclers in choosing the right material for their specific applications.

There are three major categories of polymers: thermoplastics, thermosets, and elastomers. Each type of plastic exhibits distinct molecular structures and responses to heat and deformation, leading to diverse applications and recycling capabilities. **Error! Not a valid bookmark self-reference.** compares these three categories.

**Table 4 Comparison of Plastic Properties**

Property	Thermoplastics	Thermosets	Elastomers
<b>Molecular Structure</b>	Long chain molecules with linear bonding	Amorphous network with cross-linked bonding	Amorphous linear bonding with occasional cross-linking
<b>Behaviour with Heat</b>	Bonds break upon heating, allowing molecules to move freely and melt; reform upon cooling	Covalent cross-links set molecules in place, cannot be remelted; decompose when heated above Tg <sup>6</sup>	Already excited molecules at room temperature, can deform and return to original shape due to cross-links
<b>Recyclability</b>	Can be melted and reshaped multiple times, recyclable. (mechanically recyclable)	Cannot be remelted, decompose instead. (not chemically recyclable)	-
<b>Other properties<sup>7</sup></b>	Stabilisation can be achieved in 10 seconds. Good mechanical properties and easy processing. Insoluble in organic solvents.	They can withstand high temperatures. Up to 5 minutes to stabilise. High thermal and chemical resistance. Insoluble.	-

Plastics with resin numbers 1-6 are all thermoplastics and are suitable for mechanical recycling and reforming (Grigore, 2017).

<sup>6</sup> glass transition.

<sup>7</sup> Inifitiaresearch, 2022

- Crystalline thermoplastics: typically translucent with a regular arrangement of molecular chains. These polymers have greater mechanical impact resistance. E.g., polypropylene (PP), low-density polyethylene (LDPE), and high-density polyethylene (HDPE).
- Amorphous thermoplastics: transparent with randomly arranged molecules. E.g., poly vinyl chloride (PVC), polycarbonate (PC), polystyrene (PS).
- Polyethylene (PET) can be both, with PET Bottles being made from crystalline Polyethylene and PET trays being made from amorphous polyethylene. Other resins can also be used in both forms.

Importantly, thermoset plastics, due to their cross-linked structure, cannot be mechanically recycled like thermoplastics, which can be melted and reshaped. Due to this, the same machinery that are primarily used to manufacture thermoset plastics products cannot again be used to reform thermoset plastics. The process for thermosets requires several highly complex chemical recycling processes before being reintroduced to the product line as a recycled material.

To close the loop on thermoset recycling, there has been two prominent approaches adopted: 1. incorporating dynamic covalent linkers in the plastic and 2. chemical recycling (Nicholls and Brett, 2024). Despite these advancements, however, emerging chemical recycling technologies are currently well beyond the financial means and technical capability of the Pacific with many being in the research and development stage.

## A Note on Biodegradable vs Non-Biodegradable Plastics

Non-biodegradable plastics consist of conventional raw materials (e.g., usually hydrocarbons obtained from crude oil or natural gas, though biomass can also be used) and these plastics take hundreds of years to degrade naturally. Accordingly, non-biodegradable plastics are considered one of the highest levels of environmental pollution in the world (Nayanathara Thathsarani Pilapitiya & Ratnayake, 2024).

So called 'biodegradable plastics' can also be made from either synthetic (fossil fuels) or organic (biomass sources of carbon and hydrogen). But it includes materials that contain plastics in a starch framework that rapidly release microplastics, it can contain organic materials that do not contain synthetic plastic but are very difficult to break down. The EU and OECD countries, including Australia and New Zealand consider current 'bioplastics' have the same or similar risks to other single use plastics and have, as a result also included them in plastic bans.

Recycling involves transforming plastic waste into secondary materials that can be reintegrated into the system, either for reuse in the same capacity or for creating new components and products with comparable or enhanced functionality. This approach aims to effectively 'close the loop' by minimising waste and maximising the utilisation of recycled materials within the circular economic framework.

### Key point

- Only thermoplastics are suitable for mechanical recycling (Resin no. 1 - 6)
- Priority plastics by volume are PET, PS, LDPE, HDPE and PP (in order).
- Deprioritise "Other" and PVC
- PET and HDPE are among the most easily recyclable plastics, while LDPE, PP, and PS can be more challenging due to difficulties such as inconsistent quality or economic viability that will need to be overcome.
- PVC is one of the least recyclable plastics due to additives and potential harm from its disposal will not be a target plastic.
- Avoid mixing biodegradable and non-biodegradable plastics



## 2.3 Plastics Recycling Value Chain

An analysis of the plastics recycling value chain is summarised in Figure 1. The arrows highlighted in red indicate the focus areas for this study.



**Figure 1. Plastics recycling value chain**

Source: SPREP (2020A)

**Collection** – Plastic waste needs to be collected, ideally through source separation by households and businesses. Collection can happen through curb side pickup using standard collection trucks, community collection points with bins/cages, or deposit/refund schemes for beverage containers and other plastics.

**Separation and washing** – After collection, plastics need to be further separated by resin type (e.g. PET, HDPE, PP) as different plastics cannot be recycled together. Although this can be done using automated sorting equipment like conveyor belts, magnets, and robotic sorting stations, in the PICs context it is more likely to be done manually. Sorted plastics will have to undergo a washing process to remove contamination.

**Compaction and shredding** – To reduce volume for easier storage and transportation, plastics can be compacted into bales using balers or bin compactors. Alternatively, they can be shredded into flakes or smaller pieces using shredding equipment or into plastic pellets.

**Processing** – The compacted or shredded plastic can potentially be processed further in the Pacific islands through melting, extruding, moulding or reforming it into new products like furniture, building materials, or 3D printing filament using specialised equipment.

**Waste-to-energy conversion** – Plastics can be converted into energy through thermal technologies like incineration, pyrolysis, or solid fuel production in combination with biomass. Waste-to-energy conversion technologies are not explored in detail this study as these technologies require significant capital investment and are not likely to be viable for the micro-to-small enterprises considered in this study.

## 2.4 Mechanical and Chemical Treatment and Energy Recovery

The ASTM D5033 categorises recycling into four stages.

- Primary recycling involves turning scrap materials into new products with similar qualities to the original.
- Secondary recycling creates products with slightly lower qualities from used materials.
- Tertiary recycling focuses on recovering valuable chemicals from the materials.
- Quaternary recycling focuses on obtaining energy from the recycling process.

**Table 5 Terminology used in different types of plastics recycling and recovery (Hopewell et al., 2009).**

ASTM D5033	ISO 15270	Other Equivalent Terms
<b>Primary recycling</b>	Mechanical recycling	Closed-loop recycling
<b>Secondary recycling</b>	Mechanical recycling	Down-grading
<b>Tertiary recycling</b>	Chemical recycling	Feedstock recycling
<b>Quaternary recycling</b>	Energy recovery	Valorisation

The argument for prioritising mechanical recycling over chemical recycling and energy recovery technologies is emphasised in Figure 2. Beyond avoidance and reduction and reuse, this prioritisation underscores the significance of using mechanical recycling methods first, before considering chemical recycling and energy recovery technologies, particularly in cases where critical success factors include resource efficiency, feedstock volumes available and technical skill alignment<sup>8</sup>, such is the case in the Pacific. Figure 3 below further illustrates the increasing environmental impacts of recycling plastics in a global context. It highlights that there is a correlation between greater efforts in collection and separation and reduced environmental impacts. Conversely, this means that where there are lower efforts in material separation, there is an increase in the environmental impact of the management technology choice.

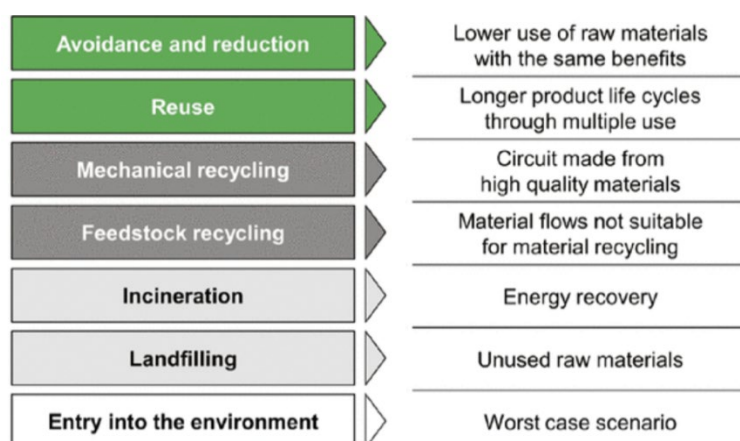

**Figure 2 Routes for dealing with plastic (Niessner and Norbert, 2022).**

<sup>8</sup> Skill requirements of the technologies that are aligned to the available local skillsets.

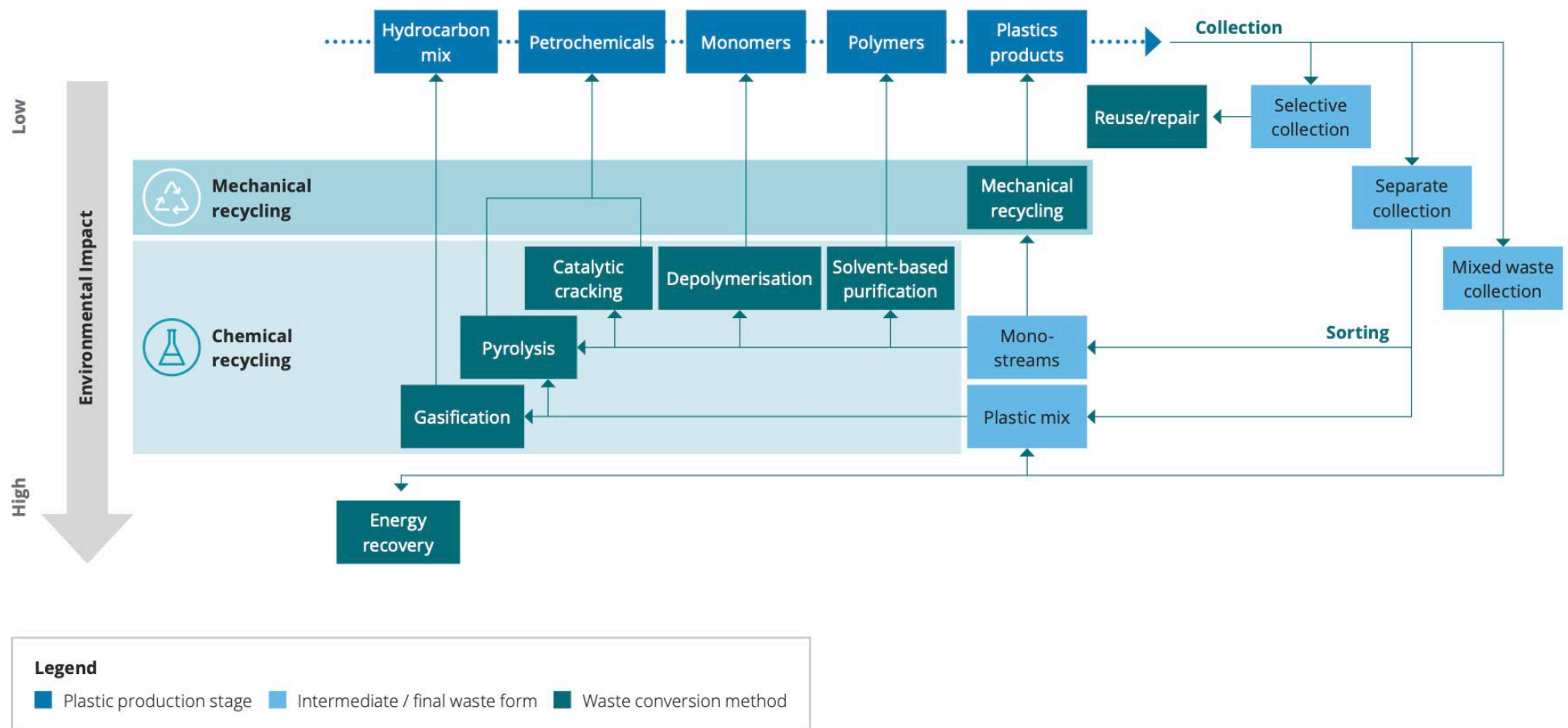

Figure 3 Recycling technologies and their environmental impact (Deloitte, 2021).

The table below presents a comparison of mechanical and chemical treatment methods.

**Table 6 Mechanical and Chemical comparison (Ehsan et al, 2023; Vollmer et al., 2020).**

Mechanical Recycling	Advantages		Chemical Recycling
	- Primary recycling leads to theoretically zero waste.	- Produces products like fuels and char.	
	- Straightforward process.	- Faster monomer rates with shorter reaction times.	
	- Requires low-skilled labour.	- Higher potential for profitability through new materials.	
	- Simple and cost-effective facilities.	- Cost-effective for recycling high-performance composites.	
	Disadvantages		
	- High energy consumption.	- High investment and technical requirements.	
	- Recycled materials often have low durability.	- Requires clean inputs.	
	- Generates some by-products.	- Produces toxic by-products.	
	- External contaminations must be removed.	- Desorption of other substances in the polymer.	
- Advanced technologies required.	- Poorly managed treatment plants may cause issues.		
- Not suitable for multi-layered waste.	- Resulting solids often need to be disposed in landfills.		
- Material quality decreases after several cycles.	- <b>Expensive investment in technical infrastructure.</b>		
- Generation of cyclic and linear oligomers affects	- <b>Feasibility at an industrial scale not fully established.</b>		
- low printability and dyeability.	- High temperatures and energy consumption required.		

## Mechanical Recycling

Mechanical recycling, also termed primary/secondary recycling or closed-loop, is a method primarily used for single-polymer plastics like PE, PP, and PS, aiming to produce clear, clean, and uniform end-products (Al-Salem et al., 2009). It is a commonly utilised recycling approach for plastics due to its comparatively low costs and low technical complexity compared the chemical recycling and energy recovery. Mechanical recycling is highly versatile with applications in small single unit creating feedstock purposes for 3D printing, various small to large moulding uses, or in very large units producing thousands of shipping container loads of flakes, granules or pellets.

Despite its low-cost nature and minimal alteration to the chemical structure, it faces challenges due to the complexity and contamination of plastic waste. Steps such as separation, washing, and preparation are crucial to address contamination, yet the heterogeneity and degradation of plastic waste remain significant hurdles. Therefore, efficient segregation processes are essential for preserving the quality of materials during recycling, maintaining as high quality as possible.

While achieving a high purity of recycled plastic, the plastics face further limitations in their ability to undergo repeated reprocessing cycles due to thermo-mechanical degradation induced by shearing forces and high-temperature processing conditions and by exposure to air, light, moisture, temperature, and weathering (Chappell et al., 2022). This degradation reduces the material's structural integrity over successive recycling iterations, limiting its suitability for further reprocessing and affecting the overall efficiency of recycling efforts. Though, this impact is reduced by incorporating as many heating cycles as possible into a single sequence (without cooling events) minimising the degree of degradation (Chappell et al., 2022). Further strategies to limit these effects include melt blending with polyethylene, filler reinforcement and mechano-chemistry, or simply blending with the same polymer in its virgin form or least cycled form.

However, within the Pacific context, the volume of circulating recycled plastic materials is greatly outpaced by the sheer volume of virgin materials in circulation. Thus, the issue of degradation of plastics after multiple iterations should not deter the attention of mechanical recycling initiatives.

## Chemical Recycling

Chemical recycling, also termed tertiary recycling or feedstock recycling, is an advanced process (both complex and expensive) to recover the building blocks of plastic from their end-of-life plastic materials and are used to produces various fuel fractions or in a new polymerisation process to produce new materials. This stands in contrast to mechanical recycling, which focuses on reshaping plastic without altering its chemical composition. The overarching goal of these processes is to maintain the integrity of the monomers within the material cycle, thus avoiding any degradation in quality often associated with downcycling (Niessner and Norbert, 2022).

Chemical recycling follows several processes: depolymerisation (hydrolysis, glycolysis, alcoholysis, ammonolysis), and thermolysis (pyrolysis, gasification) (Nayanathara Thathsarani Pilapitiya & Ratnayake, 2024; Niessner and Norbert, 2022; Al-Salem et al., 2009; Vollmer et al., 2020).

- Depolymerisation: Breaks polymer bonds to make smaller molecules called monomers or oligomers.
- Solvolysis: Uses water, alcohol, or ammonia to break certain types of polymer bonds.
- Dissolution/Precipitation: Dissolves plastic to remove impurities and recover pure polymers.
- Pyrolysis: Heats plastic in the absence of oxygen to produce a mix of different hydrocarbons.
- Gasification: Heats plastic with controlled oxygen or steam to break it into simpler molecules.

In general, chemical recycling processes are considered when mechanical recycling is not possible (Niessner and Norbert, 2022). Chemical recycling, however, poses significant challenges for implementation, particularly on a global scale and even more so for small island developing countries. It typically requires large-scale operations to achieve economic viability involving substantial investment and expertise and is further complicated by the ongoing development of processes for many plastics. Consequently, only a limited number of companies are actively pursuing commercial-scale solutions in this domain internationally and it is yet to have a proven technical and commercial business case.

Given these complexities, chemical recycling exceeds the capabilities of 'micro-small enterprises' in PICs targeted by this project. Chemical recycling will not be explored as a feasible solution within the current scope.

## Energy Recovery

Plastic waste undergoes combustion to generate energy in the form of heat, steam, and electricity (Ragaert et al., 2017). Consequently, this incineration process leads to a significant reduction in the volume of plastic (and other) waste material. Thermal recycling methods encompass various techniques, including municipal waste combustion, grate technology, fluidised bed combustion, and two-stage incineration.

Energy recovery, also termed quaternary or valorisation, (i.e., waste to energy) using plastic waste as feedstock is considered a transitional practice toward a more circular approach but not strictly circular in the traditional sense. This is because in a linear economy (left in Figure 4), resources are extracted (take), turned into a product (make), used (use), and then disposed of (waste). In contrast, the circular economy (right in Figure 4) seeks to minimise waste and keep resources in use for as long as possible through strategies like reuse, recycling, and regeneration. Energy recovery involves converting waste materials into usable energy (which aligns with the circular economy's goal of extracting value from resources that would otherwise be discarded), however, since it still involves the consumption of resources it is in conflict with the central tenets of the circular economy principles of reducing material usage and extending product lifecycles.

There are a few mostly small examples of energy recovery in the Pacific for plastics. Nufuels Ltd.'s pyrolysis operation in the Solomon Islands is at the micro-scale and focuses on converting waste plastic bags and bottles into energy (SPREP, 2021). The resulting oil, comparable to diesel, is used to fuel 'rocket stove' systems for baking and drying, while the gas is harnessed for cooking and powering petrol gensets. The feedstock is confined to plastic bags/film and bottles to prevent the production of hazardous by-products during pyrolysis. It is a very basic operation, but has been developed, implemented and run by a Solomon Islands citizen.

Likewise, Palau's Koror State Government Energy Recovery Facility operates on a slightly larger scale than Nufuel's (continuous extraction of 1,000 litres of oil from 1,000kg of plastic per 24 hours) and accepts polypropylene (PP) and polyethylene (PE) wastes (JICA, 2016). The CBA previously shared by JICA shows that while this is technically interesting it does not have a viable business case. The technology was provided by JICA who also supports its ongoing maintenance.

There is also a scaled up gasification plant in Samoa, the Afolau gasification plant was commissioned in November 2020 with an investment of \$11.3 million tala (SPREP, 2021). However, the plant is being fuelled by biomass from invasive weed and coconut logs, husks and shells to generate syngas, not by plastics, and up to a rate of 24 tons per day (7000 tons p/a).

If plastic waste was considered as a feed stock for such a gasification plant the supply of plastic waste required to operate such a system would only be possible in the larger PICs (PNG, Fiji, Solomon Islands, and potentially

Vanuatu), and insufficient for the remaining PICs. Typically, though the business case, policy implications and technical capability result in energy recovery being unviable at scale for the Pacific.

Plastic waste volumes may also decrease as waste legislative measures, such as plastic bag bans, single use plastic bans, import restrictions on PET bottles or Container Deposit Legislation (CDL) eliminate or direct plastic waste so it would be unavailable for energy use technologies. For instance, starting from 1 September 2023, the import, manufacture, distribution, supply and sale of plastic shopping bags, plastic straws, cups, plates and cutleries, polystyrene takeaway products and polyethylene terephthalate (PET) bottles for drinking water that can contain less than 1.5 litres is prohibited in the Solomon Islands, while such bans are already prevalent in most PICs. These bans and redirection of PET to CDL for export would materially impact the sustainability of even micro scale plastic pyrolysis operations.

Given the specific aim of this project is to investigate plastic recycling technologies that promote circularity for micro to small enterprises, the inclusion of energy recovery methods, which often do not reintroduce products into the circular economy, are not strongly aligned with the primary objectives. Therefore, this study will focus solely on technologies that directly contribute to closing the loop on plastic waste within a viable circular economy framework for the Pacific.

## Circular Economy

The circular economy approach to plastic recycling revolves around three core principles: reducing plastic waste and pollution through thoughtful product design, retaining resources and products in use by promoting reuse and effective recycling systems, and actively regenerating and preserving natural systems affected by plastic pollution (Nayanathara Thathsarani Pilapitiya & Ratnayake, 2024).

1. it emphasises designing products with recyclable materials and minimising single-use plastics to reduce waste generation.
2. it encourages extending the lifespan of plastic products through reuse initiatives and efficient recycling processes, thus maximising resource efficiency.
3. it tackles plastic pollution by cleaning up existing waste, preventing further contamination, and investing in technologies to regenerate plastic into new products, thereby reducing reliance on virgin materials and conserving natural resources.

Through these principles, the circular economy for plastic recycling aims to close the loop (Figure 4), mitigating environmental harm while fostering sustainable economic growth.

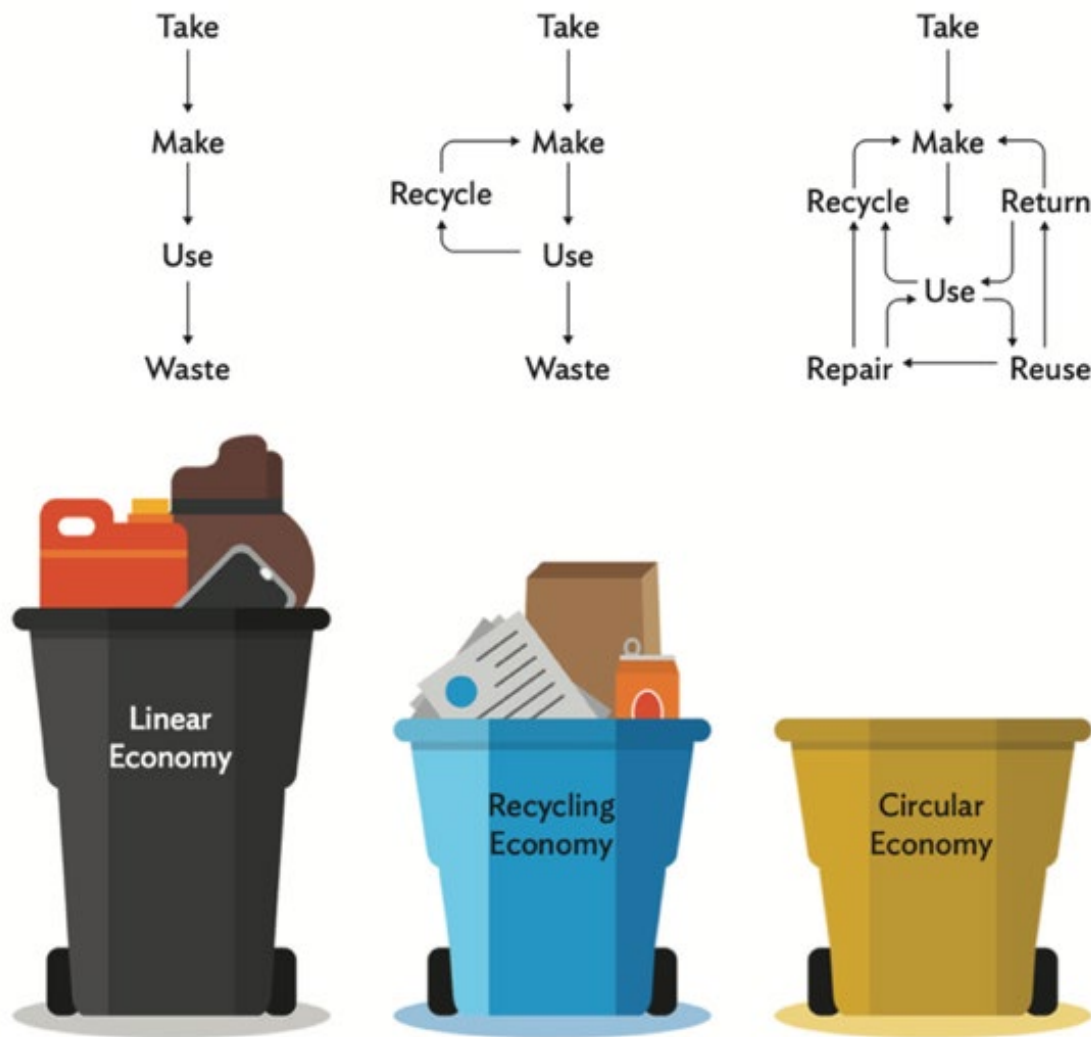

Figure 4 Simplified Circular Economy (ADB, 2020)

#### Key point

- Chemical recycling and energy recovery will not be pursued further in this analysis.
- Mechanical recycling reshapes plastic without altering its chemical composition and chemical recycling is an advanced process aiming to recover plastic building blocks.
- The issue of degradation of plastics after multiple iterations should not deter the attention of mechanical recycling initiatives as volume of circulating recycled plastic materials is greatly outpaced by the sheer volume of virgin materials in circulation.
- Mechanical recycling is widely used for single-polymer plastics due to its cost-effectiveness, but it faces challenges in maintaining material quality from contamination and degradation.



## 2.5 Capital and Operational Requirements

### Land and Facility

The ideal location and facility for recycling practices should have these features:

- Should have easy access to major road and utilities.
- Considerate of potential impacts e.g., noise and air pollution to neighbouring communities.
- Well-ventilated to prevent air pollutants from impacting worker health.
- Adequate space for storing plastic waste stockpiles.

### Equipment and Machinery

Plastics recycling is a potentially dangerous and risky activity to workers due to the handling of hazardous substances. As such, they will need to be adequately equipped with necessary personal protective equipment (PPE) to enable them to safely take on tasks on the site.

Key PPE include:

- Helmet or head protection
- Gloves
- Eye protection or safety goggles
- Face mask/visor
- Safety boots or closed toe shoes

### Labour

The number of workers required will require on the labour requirements of the various machinery. Volunteers can be drawn on to assist in beach clean-ups and gathering of plastic waste for recycling through established or emerging collection routes.

### Machinery

Machinery for small-scale mechanical recycling include extruders, moulders, and reformers (SPREP, 2020b). The cost of these machines can vary significantly depending on their features. The plastic recycling process will be discussed in two key stages. Stage 1 is the preparation stage where materials are separated, cleaned, and treated until flaked or pelletised. Stage 2 is the product development stage where materials from Stage 1 are processed into usable products.

# 3 Technologies

## 3.1 Stage 1: Plastic Feedstock Preparation Stage

At a recycling facility, waste undergoes a series of stages to ensure its suitability for recycling. Initial sorting removes impurities (i.e., removal of non-target materials that attached to or mixed in with the target materials). In the Pacific this can be achieved by hand and at the source of waste generation (i.e., the waste generator will isolate target wastes in preparation for recycling). Once impurities are removed, the target recyclable material is shredded and cleaned to reduce the size and volume.

Further steps involve the separation of foreign objects and non-resins. The remaining material is turned into flakes or is pelletised (thermally processed after granulation). These are considered as commodities which can be sold and returned to the global plastic circular economy or used to produce locally manufactured products.

**Note** that the process described below is common within developed nations and operates on a very large scale, often through well-established integrated waste management systems and co-mingled kerb-side collection. In the Pacific, not only is there an absence of Material Recycling Facilities (MRFs) that can successfully accept and recycle co-mingled waste materials, but the majority of PICs also lack an integrated waste management system and kerb-side collection. Therefore, in general, recycling businesses in the Pacific usually purchase source-separated recyclables directly from the public. It is an expectation of the seller (i.e., the person bringing the recyclable to the recycler) that the materials are clean (to an agreed upon standard) as part of the terms of purchase.

This process typically uses the following technologies:

### 1. Sorting

Pre-consumer waste can often be a relatively pure, clean, and uncontaminated source of plastic waste. Post-consumer waste, however, often contains a broad mixture of materials. In countries with long standing integrated waste management practices, the waste is transported to a sorting plant (e.g., Material Recycling Facility) and sorted by material type. This process is challenging and must implement a combination of techniques applied in varying arrangements to suit the local waste profile and political context. For example, the most commonly used separation techniques involve a complex combination of technologies; eddy current separator, sink–float separation, drum separators/screens, induction sorting, X-ray technology and near infrared (NIR) sensors (Shen and Worrell, 2014).

In the Pacific, separation can be affordably achieved through a combination of manual sorting and separating desired materials at the source (i.e., source-separation) through deliberate and target social behaviour change campaigns and incentives such as competitive pricing for feedstock waste materials.

Sorting is arguably one of the most critical steps in the recycling process as it is often the point at which low cost pathways can be prioritised (i.e., by eliminating reliance on downstream costly technologies such as float separators). For instance, it is especially difficult to distinguish polyvinyl chloride bottles (PVC) from PET bottles once they have been shredded and even at small concentrations PVC will cause significant reduction in quality of entire batches of melted PET.

**2. Cutting/Shredding/Granulating:** Plastic materials of all shapes and sizes are cut by shear or saw to reduce volume and fit into the shredder hopper.

While both machines (granulators and shredders) achieve size reduction there are several key differences that can determine the pathway for the output material. Those key differences are outlined in **Error! Not a valid bookmark self-reference..**

**Table 7 Key differences between granulator and shredder machines.**

Aspect	Shredder	Granulator
<b>Particle Size and Shape</b>	Tear materials apart using high torque and low speed, resulting in larger irregularly sized pieces compared to granulators.	Produce fine, uniform particles resembling the original material through shearing mechanism similar to scissors.
<b>Cutting Mechanism</b>	Use tearing mechanism to rip materials apart forcefully.	Employ an open-rotor design for precise cutting.
<b>Speed and Capacity</b>	Work at lower speeds but with high torque, handling larger and heavier scraps.	Operate at high speeds with low torque, efficiently processing smaller materials.

Ultimately, the choice between granulator and shredder machines should focus on the requirements of the output material. That is, for example, if the aim of the recycling operation is to sell the plastic output where it will undergo further reprocessing, a shredder can achieve this quickly and efficiently. If the primary aim is to reduce size for remelting, size consistency is priority, and a granulator machine may be most suitable.

However, the best solution may not necessarily be an either-or choice. Some processes may benefit from integrating both granulators and shredders to achieve comprehensive size reduction solutions to balance the limitations of each technology. Shredding acts a primary size reduction step of large materials that would otherwise jam granulators. This is then followed by the granulation process to achieve consistent output.

## Shredder

**Why Choose Shredder?** For efficient and versatile processing of plastic waste, capable of reducing large pieces into smaller fragments or pieces, ideal for initial size reduction in plastic recycling processes.

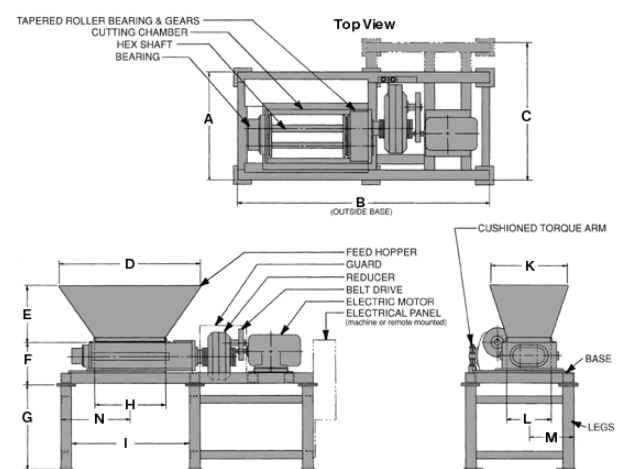

**Figure 5 Twin shaft shredder**

**Table 8 Shredder characteristics**

<b>Process</b>	Plastics are fed into the shredder hopper to be processed into flakes where a combination of cutting, shredding and tearing forces pull apart plastic. Every design of shredder consists of: (i) a shaft and sets of blades, (ii) a motor, gearing, bearing and transmission (iii) hopper and (iv) a framework <sup>9</sup> . The combination of static blades and rotating blades shear the plastic repeatedly until a desired size is achieved and the plastic shreds fall through.
<b>Skills required</b>	<b>Basic:</b> This process involves relatively simple equipment and procedures. Machine components requiring regular maintenance due to wear and tear during the shredding process are shredder’s shaft and sets of blades. Thus, operators need a fundamental understanding of machine operation, safety protocols, and basic material handling. Training can be completed relatively quickly and made accessible to individuals with minimal experience. It is suitable for micro and small enterprises with limited resources and workforce capacity.
<b>Suitability for micro-small enterprise</b>	<b>High:</b> This process is simple, has low initial investment, is efficient and results in a pile of plastic flake that are easy to store without additional equipment.
<b>Throughput</b>	Range: 150 to 2,994 kg/hr. Generally has a higher minimum throughput volume to be efficient.
<b>Plastic types</b>	Polyethylene (PE), polypropylene (PP), and polystyrene (PS), Acrylonitrile butadiene styrene (ABS), polycarbonate (PC), and high density polyethylene (HDPE).
<b>Example products</b>	Product is shredded plastic flake; <i>as is</i> .

In small to medium shredder machines, single and double shafts may be sufficient (Wong et al., 2022). Larger machines and machines with more shafts will increase maintenance costs.

**Table 9 Shredder shaft types for soft or rigid plastics (Lau, 2023).**

Shaft Type	Suitability	Processing Plastics
<b>Single shaft shredders</b>	For processing softer plastics, such as films, and producing smaller output sizes	Polyethylene (PE), polypropylene (PP), and polystyrene (PS)
<b>Twin shaft shredders</b>	For processing thicker, more rigid plastics, such as pipes and car parts, and producing larger output sizes	Acrylonitrile butadiene styrene (ABS), polycarbonate (PC), polypropylene (PP), and high density polyethylene (HDPE)

<sup>9</sup> Al-Salem et al., 2009

## Granulator

### Why Choose a Granulator?

Essential for precision to finely grind or cut plastic waste into uniformly sized granules, ensuring consistency in material quality and facilitating downstream processing and reuse.

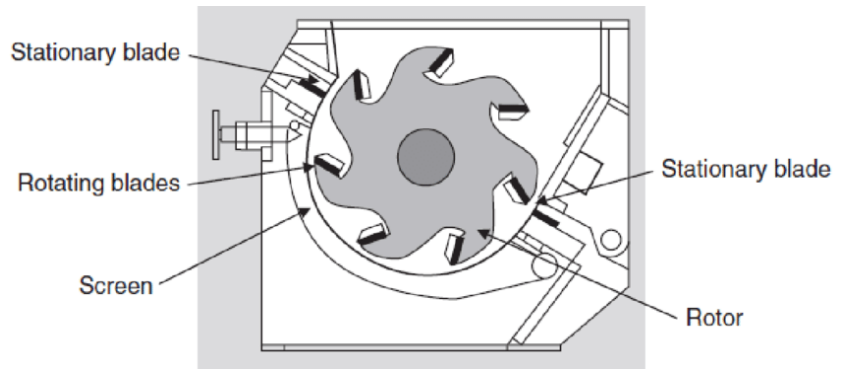

Figure 6 Granulator

Table 10 Granulator characteristics

<b>Process</b>	Smaller plastics are fed into the granulator to be processed into granules of consistent size. The feed material is allowed to fall through the feed shaft into the cutting chamber where the material is repeatedly reduced in size by cutting between the rotor and stator blades (Figure 6). The cutting process continues until the material is passed through the built-in screening sieve (The sieve perforation can be adapted to the required particle size of the material.) as ground material.
<b>Skills required</b>	<b>Basic to intermediate:</b> This process involves relatively simple equipment and procedures. Machine components require regular maintenance due to wear and tear during the granulation process. Operators must be capable of troubleshooting common issues and adjusting to optimise production. Training can be completed relatively quickly and made accessible to individuals with minimal experience. It is suitable for micro and small enterprises with limited resources and workforce capacity.
<b>Suitability for micro-small enterprise</b>	<b>High:</b> This process is simple, has low initial investment, is efficient and results in a pile of plastic granules that are easy to store without additional equipment and have higher market value than shredded plastic. The minimum throughput volume rate is low and can suit any size operation. The only real limitation is the size and configuration of the feed opening and cutting chamber.
<b>Throughput</b>	Range: 4 to 600 kg/hr for small business. Virtually no minimum throughput limit but for frequent high-volume scrap may be less efficient.
<b>Plastic types</b>	Polyethylene (PE), polypropylene (PP), and polystyrene (PS), Acrylonitrile butadiene styrene (ABS), polycarbonate (PC), and high density polyethylene (HDPE)
<b>Example products</b>	Product is granulated plastic; <i>as is</i> .

Granulation is possible for both rigid and soft plastic however there are several machine choice considerations to note if targeting soft plastics.

- High speed or low speed granulators.
  - Low-speed granulators are typically designed to handle softer materials.
  - High-speed granulators are more commonly used for processing harder plastics and may not be suitable for soft plastic materials.
- Some soft plastics may be more prone to melting or deforming when subjected to mechanical forces in a granulator.
- Preparing soft plastic materials for granulation may involve shredding or pre-processing them to reduce their size and ensure uniform feeding into the granulator.

**3. Contamination Removal:** Paper, dust and other forms of impurities (e.g., metals) are separated from plastic by hand (micro enterprise) or by cyclone separator or rotating drum and fan (larger enterprises).

**4. Mixed Plastic Separation:** Once non-plastic contamination is addressed, there are two major approaches to separating mixed plastics: Wet and Dry separating techniques.

This step might be necessary for larger operations approaching the upper limits of small sized enterprises where plastic is received in large, comingled volumes such as from kerb-side collection. However, it may also be entirely avoidable where plastic waste is pre-sorted (i.e., source separated) by polymer type.

4.1 Wet separation techniques (Dodbiba & Fujita, 2004) are used to separate mixed plastics in the presence of water or wetting agents. These techniques typically use processes like flotation, where plastics are selectively separated based on their wetting characteristics, or sink-float separation, which relies on the differences in density between plastics to separate them. Density-based sorting techniques are common, especially for polyolefins which means, unless significantly altered, they typically have a density lower than  $1.0 \text{ g/cm}^3$  and therefore float on water (Niessner and Norbert, 2022). This characteristic allows for straightforward separation of the polyolefin fraction from a batch stream by simply immersing it in a water bath. Elsewise, wet separation techniques often involve the use of several wetting reagents or chemicals to modify the surface properties of plastics and facilitate their separation. Additionally, these techniques may require multiple steps or processes to achieve desired levels of purity and recovery. Despite their effectiveness in recovering plastics, wet separation techniques have drawbacks such as the need for water treatment, the use of expensive reagents, and the challenge of dewatering and drying the separated materials.

#### **Density Floating:**

Different types of plastic flakes are separated in a floating tank according to their density. Importantly, to achieve the highest yield requires a uniform particle geometry which is most suitable for products of the granulation process rather than shredding. However, due to the competitive nature of plastic recycling business published industrial density plastic separation processes are notably vague or absent in the literature, limiting access to general specifications (Gent et al., 2009).

## Separation Tank

**Why Choose a Separation Tank?** For efficient separation of different types of plastics based on their densities; ideal for sorting and facilitating downstream processing for higher-quality recycled materials in larger operations.

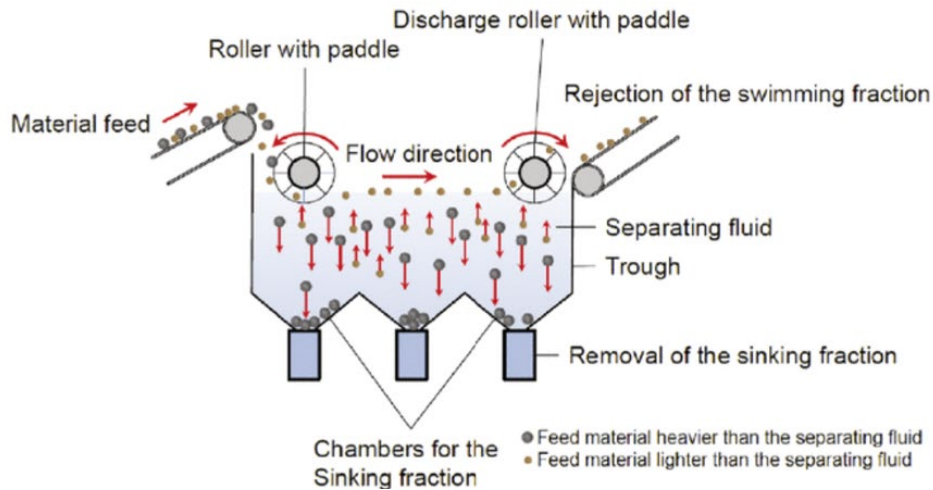

Figure 7 Continuous float-sink separator <sup>10</sup>.

Table 11 Sink-Float Separation Tank characteristics.

<b>Process</b>	A separation medium that has a density between the densities of the plastics to be separated is selected. Continuous separators (Figure 7) consist of one or more open basins filled with separating liquid and equipped with charging and discharging device to separate multiple plastics in one flow. The flow rate is controlled to allow particles to float or sink according to their density. Discharge mechanisms, such as paddles or rollers, separate the floating and sinking materials at the end of the basin, while dividing the basin bottom into chambers facilitates the collection of distinct sink fractions.
<b>Skills required</b>	<b>Advanced:</b> False discharges may occur due to air bubbles adhering to insufficiently wetted particles. To enhance wetting, wetting agents can be added to the separating liquid. These processes demand high knowledge of complex machinery, intricate process control, and troubleshooting techniques. Operators must be capable of analysing and addressing complex problems to ensure consistent and high-quality output. This process may be suitable for small enterprises with 10-49 employees with access to specialised training resource.
<b>Suitability for micro-small enterprise</b>	<b>Low to Moderate:</b> The process involves complex machinery with a higher expertise expectation and is less suitable for micro to small enterprises. While it may offer certain benefits in terms of product quality, the barriers to entry, such as skill requirements may limit the adoption by smaller businesses.
<b>Plastic types</b>	The float-sink separators in use are designed almost exclusively for polyolefin separation (i.e., separating polyethylene and polypropylene from other plastics).
<b>Example products</b>	Isolated plastics by resin type, and commonly by polyolefin and non- polyolefin factions.

<sup>10</sup> Image from Niessner and Norbert, 2022

4.2 Dry separation techniques (Dodbiba & Fujita, 2004) are used to separate mixed plastics without the use of water or wetting agents. These techniques often used in automated sorting systems using near-infrared spectroscopic analysis, optical filters, or other sophisticated technologies for accurate sorting based on resin type or colour. Dry gravity separation methods, such as vertical air classifiers or air tables, take advantage of differences in density to separate plastics effectively. Electrostatic separation techniques, including corona charging and triboelectric separation, are also employed to separate plastics based on their electrical properties. Triboelectric separation, which uses frictional charging, is particularly effective in selectively separating different types of solid dielectric materials. These techniques offer advantages such as low capital and operating costs, environmental friendliness, and high separation efficiencies which do not require the need for water treatment, the use of expensive reagents, or dewatering and drying of the separated materials.

**5. Washing and drying** (Shen and Worrell, 2014): Washing can be achieved with either cold or hot water, up to 60 °C. Chemical washing may also be employed in certain cases (mainly for glue removal from plastic), where caustic soda and surfactants are used. The use of cold water may result in increased need for chemicals (e.g. sodium hydroxide) and mechanical energy. The washed plastic flakes are dried until they contain less than 0.1 wt% moisture and are ready for reprocessing (mechanical dryer or thermal dryer).

### Friction Washer

**Why Choose a Friction Washer?** For thorough cleaning to remove contaminants and impurities from shredded plastic materials, ideal for production of clean and high-quality recycled plastics.

**Table 12 Friction Washer characteristics.**

<b>Process</b>	Usually, the friction washer sits on an incline frame (Figure 8). Inside, a part called the inner paddle configuration moves the plastic pieces upward while washing them. A strong centrifugal force removes fines, water, and wet paper from the plastic. All residues exit through a pipe at the bottom of the washer.
<b>Skills required</b>	<b>Intermediate:</b> Operators need to understand the operation of the friction washer, including how to set it up, adjust parameters, and monitor its performance. Basic knowledge of machine operation and safety protocols is necessary.
<b>Suitability for micro-small enterprise</b>	<b>Moderate:</b> Relatively straightforward compared to more complex recycling technologies. It could be suitable for micro to small enterprises with some training and supervision, although initial investment required may be a limiter.
<b>Plastic types</b>	Required for dewatering materials such as film flake, PET bottle flake and other rigid plastics.
<b>Example products</b>	Washed (but still wet) plastic (either shredded or granulated)



## Mechanical Dryer

**Why Choose a Mechanical Dryer?** To efficiently remove moisture from washed plastic materials, ensuring optimal conditions for further processing. Ideal for minimising energy consumption and maximising production efficiency for larger operations.

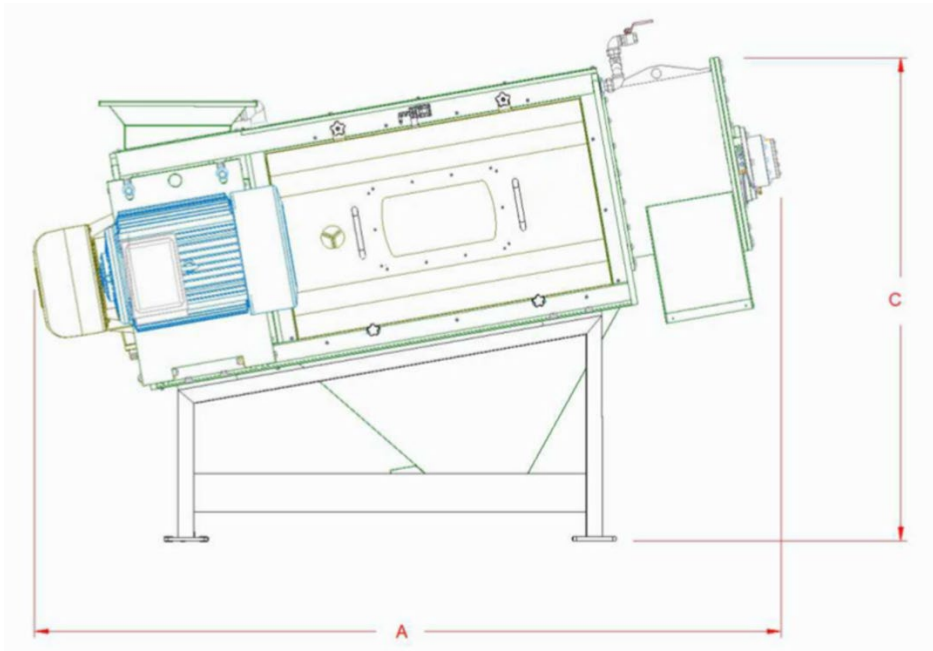

Figure 8 Friction Washer<sup>11</sup>

Table 13 Mechanical Dryer characteristics

<b>Process</b>	The input material is introduced into the upper end of the dryer. In the dryer, an inner rotor moves the flakes from the in-feed side to the discharge side. This rotor determines the total dwell travel time of the material inside the dryer and thus the moisture content of the output. The plastic is forced against the rotor and screen surface to achieve a thorough cleaning and optimal drying efficiency. Water and residual moisture are expelled from the material through screen cage.
<b>Skills required</b>	<b>Intermediate:</b> Operators need a good understanding of the mechanical dryer's operation, including how to monitor moisture levels and troubleshoot any issues that arise. Knowledge of machine operation, material properties, and process control is essential.
<b>Suitability for micro-small enterprise</b>	<b>Moderate:</b> The mechanical dryer may require a higher skill level to operate effectively due to its complexity and the need for precise control over drying parameters. It may not be as accessible to micro enterprises without significant training and investment in skilled personnel.
<b>Plastic types</b>	Plastics washed for dewatering such as film flake, PET bottle flake and other rigid plastics.
<b>Example products</b>	Dried plastic (either shredded or granulated) suitable for resale.

<sup>11</sup> Image from tecnofer.biz

## Thermal Dryer

**Why Choose a Thermal Dryer?** For effective drying using heat to evaporate moisture from washed plastic materials quickly. Ideal for rapid processing and to enhance the quality of recycled plastic products.

**Table 14 Thermal Dryer characteristics**

<b>Process</b>	The thermal dryer has the following components: Heating register, mixing element, transport blower, and a downstream spiral formed piping with final cyclone separator. To maintain consistent material heating temperature relative to the ambient temperatures the heating register has manual control of temperature.
<b>Skills required</b>	<b>Intermediate to Advanced:</b> Operators need high level of training and experience to operate the thermal dryer due to its complex heating system, temperature control, and airflow management.
<b>Suitability for micro-small enterprise</b>	<b>Low:</b> Used to further reduce the residual moisture content in material flake. Generally, thermal dryer necessary for materials that will be processed through an extruder after the washing phase. However, the specialised nature of the equipment and the need for expertise in thermal processing make it more very challenging for small operations without dedicated resources.
<b>Plastic types</b>	Plastics washed for dewatering such as film flake, PET bottle flake and other rigid plastics.
<b>Example products</b>	Dried plastic (suitable for granulated) appropriate for resale or extrusion.

**6. Reprocessing:** Plastics of identical resins are reprocessed to into pellets to improve quality and market value.

## Pelletiser

**Why Choose Extrusion?** To efficiently transform plastic waste into uniform pellets or granules, and ideal for easy storage, transportation, and further processing in various manufacturing applications.

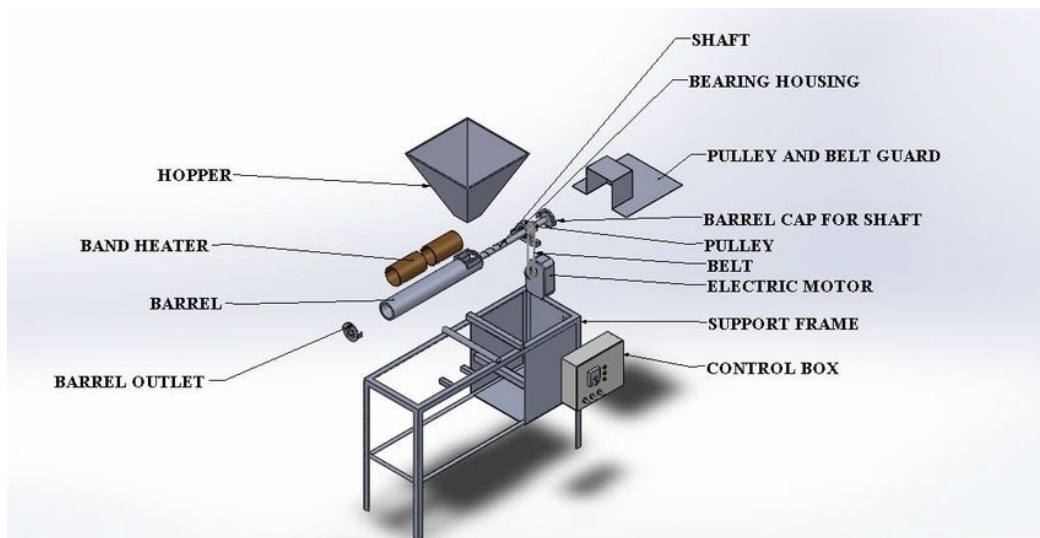

**Figure 9 Simple Pelletiser Machine**

**Table 15 Pelletiser characteristics**

<b>Process</b>	The plastic is slowly melted and passed through a die and cut by rotating blade on a motor producing cylindrical, round but flat, or spherical pellets (Figure 9).
<b>Skills required</b>	<b>Intermediate:</b> Pellet production requires knowledge of machine operation, material properties, and pelletising techniques is necessary for efficient and consistent production. While feasible for small enterprises with 10-49 employees, processes may pose challenges for micro-enterprises.
<b>Suitability for micro-small enterprise</b>	<b>High:</b> Relatively low initial investment compared to other processes. This method can be cost effective and straightforward for micro and small scale operations. Proper training and supervision required. Smaller businesses can use pelletiser machines to produce high-quality pellets from recycled plastic or other materials.
<b>Throughput</b>	Range: 2 to 3000 kg/hr. Virtually no minimum throughput limit.
<b>Plastic types</b>	PET, HDPE (good quality) and LDPE, PP, PS and PVC (to varying degrees of quality).
<b>Example products</b>	Pelletised plastic with known characteristics (i.e., resin type, density, dimensions, colour) which can be used as raw material in various manufacturing processes.

### 3.2 Stage 2: Plastic Moulding Techniques (Product Development)

After this preparation stage, the recyclable is no longer considered waste and has been transformed into a commodity. At this stage, the recycler can either (1) sell the flaked, granulated, or pelletised materials to the open market or (2) use the material in-house as feedstock for product manufacture. Under the first condition, what happens to materials after the exit point is beyond the scope of this report and is not explored further. Under the second condition, however, the following are common plastic moulding techniques suitable for mechanical recycling. For each, it is assumed the feedstock used is the pelletised material from stage 1.

#### Extrusion Moulding

**Why Choose Extrusion?** Ideal for applications requiring uniform cross-sectional shapes, like pipes, tubes, and profiles.

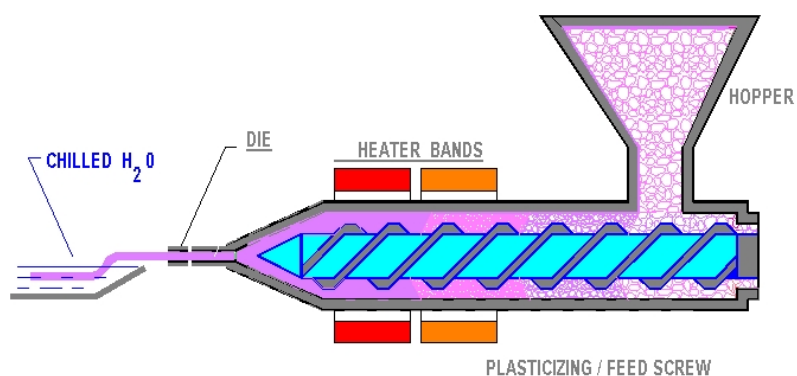

**Figure 10 Horizontal Extrusion Moulding**

**Table 16 Extrusion moulding characteristics**

<b>Process</b>	Involves melting resin or flakes and passing them through a mould via single or twin screws, resulting in the formation of a moulded product. This moulding technique is characterised by the use of die or thermoplastic material. The process liquifies the plastics, forcing them through a die to create elongated tube-like shapes which then can be threaded around a basic, free-form mould to create simple artisanal shapes.
<b>Skills required</b>	<b>Intermediate to Advanced:</b> Extrusion moulding requires a good grasp of processing parameters, quality control measures such as temperature and speed, and material properties. Knowledge of material properties, die design, and quality control is essential for achieving desired product specifications. While feasible for small enterprises with 10-49 employees, processes may pose challenges for micro-enterprises.
<b>Suitability for micro-small enterprise</b>	<b>Moderate:</b> Relatively low initial investment compared to other processes. However, unknown or mixed materials make can present challenges to design progress, especially for beginners. Once mastery is achieved, this method can be cost effective and versatile for micro and small scale operations due to its continuous production capability.
<b>Throughput</b>	Range: 1 to >10,000 kg/hr Limiting Factors: input rate for larger operations and by material flow rate for smaller operations. Flow rate is dependent on the plastic material and the screw specifications.
<b>Plastic types</b>	PET, Polyethylene (HDPE, LDPE), PVC (versatile but can release harmful chemicals if not properly handled), Polypropylene (PP), Polystyrene (PS).
<b>Example products</b>	Tubes (e.g., water or sewage pipes), rods, strips, insulated electric cables, hollow pipes, plastic decking and lumber, plastic rain gutters, sheets (e.g., protective covers, sound barriers, refrigerator liners, and decorative panels), and film (e.g., wrap, agricultural weed control, and protective packaging during shipments).

**Table 17 Common Extruder types**

Extruder Type	Description	Suitability for Recycled Plastics	Justification
Single Screw Extruders	Single screw extruders are the most common continuous extruders characterised by low cost, simple design, toughness, reliability, and high performance/cost ratio. They consist of three main sections: feed zone, transition or compression zone, and metering zone.	High	Single screw extruders offer continuous operation, efficient mixing, and effective control over pressure and temperature, making them suitable for processing recycled plastics without degradation. They have a larger melting capacity and shorter residence time compared to other extruder types.
Twin Screw Extruders	Twin screw extruders have two screws, offering various design parameters such as rotational direction and degree of intermeshing. They are continuous multiple screw	High	Twin screw extruders provide continuous operation and excellent mixing capabilities, making them suitable for processing a wide range of recycled plastics. They offer effective control over processing parameters

Extruder Type	Description	Suitability for Recycled Plastics	Justification
	extruders and result is a greater degree of melt mixing.		and have a larger melting capacity compared to other extruder types.
Disk Extruders	Disk extruders, or screwless extruders, use disks or drums instead of screws for material conveyance. They operate based on viscous drag transport.	Low	Disk extruders have limited mixing capabilities and control over processing parameters, making them less suitable for processing recycled plastics. They may not offer efficient melting capacity or effective temperature control compared to other extruder types.
Drum Extruder	Drum extruders use a rotating drum and barrel for the extrusion process. Material is fed into the space between the drum and barrel, carried along the circumference, and scraped off by a wiper bar.	Low	Drum extruders may have limitations in mixing efficiency and temperature control, making them less suitable for processing certain types of recycled plastics. They may offer limited melting capacity and longer residence times compared to other extruder types.
Single Ram Extruder	Single ram extruders, or plunger extruders, are used in discontinuous operations. They are simple, tough positive displacement devices with limited melting capacity and poor equal temperature distribution of the melt.	Low	Limited mixing capabilities and control over processing parameters like melt capacity and long residence times make them less suitable for processing recycled plastics.

## Injection Moulding

**Why Choose Injection Moulding?** Ideal for mass-producing intricate and precise plastic parts with efficiency.

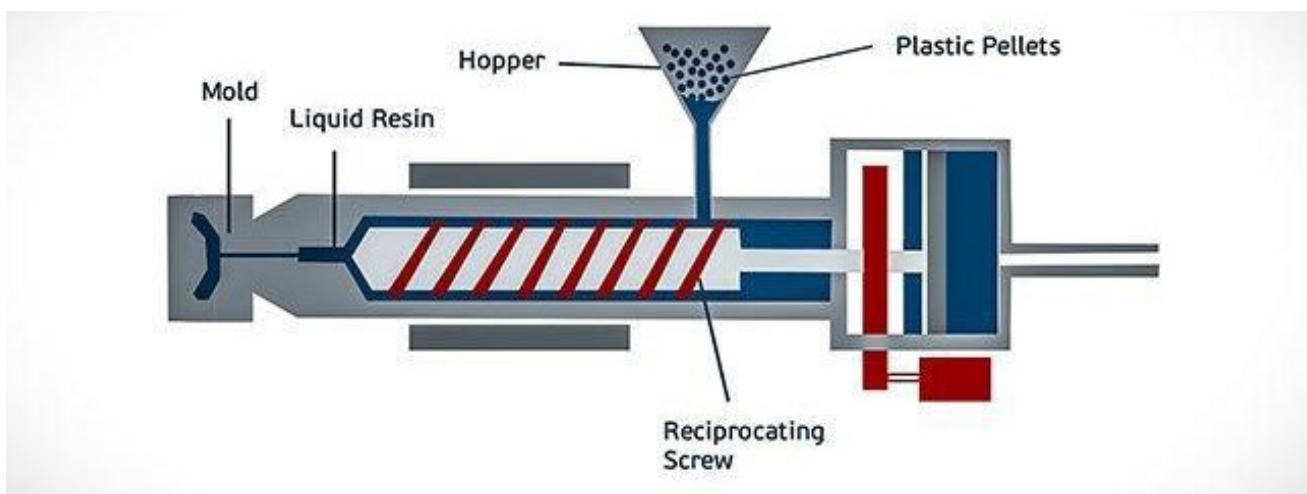

Figure 11 Injection Moulding

**Table 18 Injection moulding characteristics**

<b>Process</b>	Involves injecting heated molten resin into a mould where it will solidify and form the desired product (Figure 11). This method is highly versatile, allowing businesses to design custom moulds for a wide range of products whilst also enabling mass production of identical items. There are four common processes used (Table 19).
<b>Skills required</b>	<b>Intermediate to Advanced:</b> Injection moulding requires a good grasp of processing parameters, including mould setup, material handling, injection parameters, and machine operation. Knowledge of mould design, material behaviour, and quality assurance is crucial for achieving consistent and defect-free parts. While feasible for small enterprises with 10-49 employees, processes may pose challenges for micro-enterprises.
<b>Suitability for micro-small enterprise</b>	<b>Moderate to High:</b> Initial investment costs may be higher, but scalability allows smaller businesses to achieve economies of scale over time. Although Injection moulding requires intermediate to advanced skills, it is more accessible to micro to small enterprises compared to extrusion moulding due to its versatility and ability to produce complex parts. It offers high productivity and relatively lower per-unit costs for large production runs.
<b>Throughput</b>	Range: <1 to >3600 kg/hr Limiting Factors: material flow properties, mould design, and injection pressure.
<b>Plastic types</b>	PET, Polyethylene (HDPE, LDPE), PVC (versatile but can release harmful chemicals if not properly handled), Polypropylene (PP), Polystyrene (PS), Polymethyl Methacrylate (PMMA), Acrylonitrile Butadiene Styrene (ABS)
<b>Example products</b>	Commonly used in manufacturing various accessories such as plastic combs, hairbrushes, blow dryer casings, outdoor equipment like picnic tables, chairs, as well as toys, computer keyboards, and casings for small household appliances and automotive components such as dashboard panels

**Table 19 Four common types of injection moulding processes**

Type	Description	Suitability for Recycled Plastics	Justification
Thermoplastic injection moulding:	As the most widely used method it involves injecting thermoplastic resin into a mould where it cools to form the final part. It is a manufacturing process for creating fully functional parts by injecting plastic resin into a pre-made mould.	High	Thermoplastic injection moulding produces parts from thermoplastic resin, which can typically be melted and reshaped multiple times, making it highly suitable for using recycled plastic
Insert moulding:	This process begins with an insert component placed into the mould before resin injection (typically made of metal rather than plastic). The material is then injected, encasing the insert. Insert	High	Insert moulding typically uses thermoplastic materials and produces parts with a strong bond between the insert and the plastic, making it

Type	Description	Suitability for Recycled Plastics	Justification
	moulding streamlines production and minimises costs by eliminating secondary joining operations while benefitting from a stronger bond between the insert and the moulded components <sup>12</sup> .		suitable for using recycled plastic.
Overmoulding:	This technique is used to manufacture plastic parts using multiple materials. One thermoplastic is encased by another, creating a solid skin whose thickness is regulated by adjusting factors like injection speed, temperatures, and flow compatibilities between the two materials <sup>13</sup> . Overmoulding streamlines production and minimises costs by eliminating manual assembly of multiple components.	Moderate	Yes, but may be limited. The bonding between the layers may affect the suitability for using recycled plastic depending on the specific materials used and the strength of the bond.

## Blow Moulding

**Why Choose Blow Moulding?** Great for shaping hollow plastic objects, such as bottles and containers, through controlled inflation.

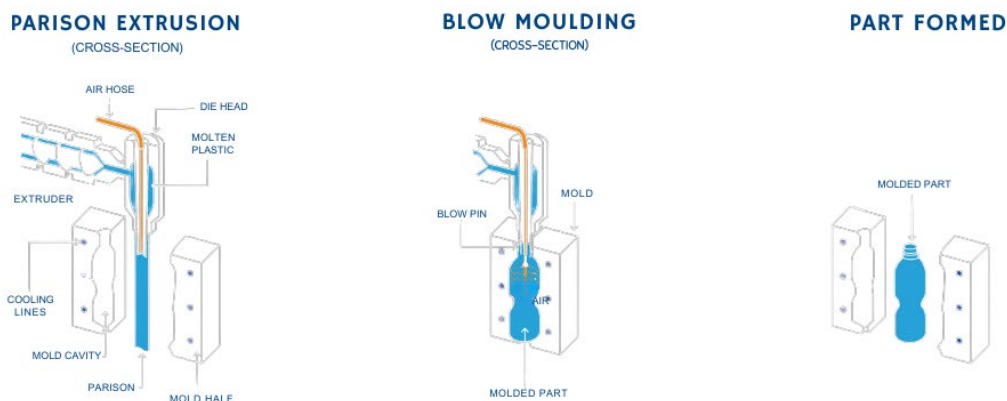

**Figure 12 Blow Moulding**

<sup>12</sup> Gemini Group, 2018

<sup>13</sup> Steven, 2021

**Table 20 Blow moulding characteristics.**

<b>Process</b>	Involves relatively simple equipment and procedures. The blow moulding process begins by extruding the parison, which is a round melted mass that will then be moulded or formed, into a hollow tube (Figure 12 Parison extrusion). Once the mould is closed with the parison securely in place, compressed air is blown into it to expand the plastic and fill the mould (Figure 12 Blow moulding). Finally, the finished product is removed from the mould and any excess plastic at the top and bottom is trimmed away (Figure 12 Part formed). There are three (3) primary types of blow moulding (Table 21).
<b>Skills required</b>	<b>Intermediate:</b> Operators need a good understanding of machine operation, including how to set up moulds, adjust parameters such as temperature and pressure. Knowledge of material behaviour, mould design, and quality control is essential for producing consistent and defect-free products. Proper training, smaller enterprises can achieve consistent results with recycled plastics.
<b>Suitability for micro-small enterprise</b>	<b>Moderate:</b> Blow moulding offers advantages such as low cost for high-volume production, a high strength-to-weight ratio, design flexibility, and insulation and acoustic properties <sup>14</sup> . However, it is crucial to select a material with suitable elastomeric properties to avoid tearing during stretching. It can be more affordable than injection moulding, making it accessible to small enterprises.
<b>Throughput</b>	Range: < 1 to >100,000 kg/hr Limiting Factors: Input quality, blow pin design and venting, and mould temperature and cooling.
<b>Plastic types</b>	High Density Polyethylene (HDPE), Low Density Polyethylene (LDPE), Polypropylene (PP), Polyvinyl Chloride (PVC), Polyethylene Terephthalate (PET), Acrylic -Styrene (PS).
<b>Example products</b>	Bottles, jars, milk jugs, and an array of food containers: Shampoo and motor oil, coolers, play structures, fuel tanks, industrial drums, garbage bins, large barrels, carrying cases, and squeeze bottles.

**Table 21 Common blow moulding techniques**

Type	Description	Suitability for Recycled Plastics	Justification
Extrusion blow moulding (as shown in Figure 12)	The most common type of blow moulding and is used to manufacture complex parts in large quantities.	High	Recycled plastic can be effectively processed and mixed into the manufacturing process without compromising the quality or integrity of the final product.
Stretch blow moulding	Typically used to create plastic containers with simple geometries such as jars and bottles to ensure resistance to rupture.	Moderate	The suitability for using recycled plastic depends on the specific requirements of the application. Simple geometries may allow for easier processing of recycled plastic, but factors such as material purity and strength

<sup>14</sup> Gemini Group, 2018



Type	Description	Suitability for Recycled Plastics	Justification
			requirements can limit suitability. With proper sorting and processing of recycled materials, stretch blow moulding can still be a viable option.
Injection blow moulding	The least commonly used method and is used to manufacture small containers in small quantities.	Low	The precision and control required in injection blow moulding may not be effective in incorporating recycled materials, as it could affect the quality and consistency of the final product. The smaller scale of production may not justify the investment in processing recycled materials for this method.

**Vacuum moulding (Thermoforming Moulding):**

**Why Choose Vacuum Moulding?** Effective for forming three-dimensional plastic shapes, like packaging and automotive components, with precision.

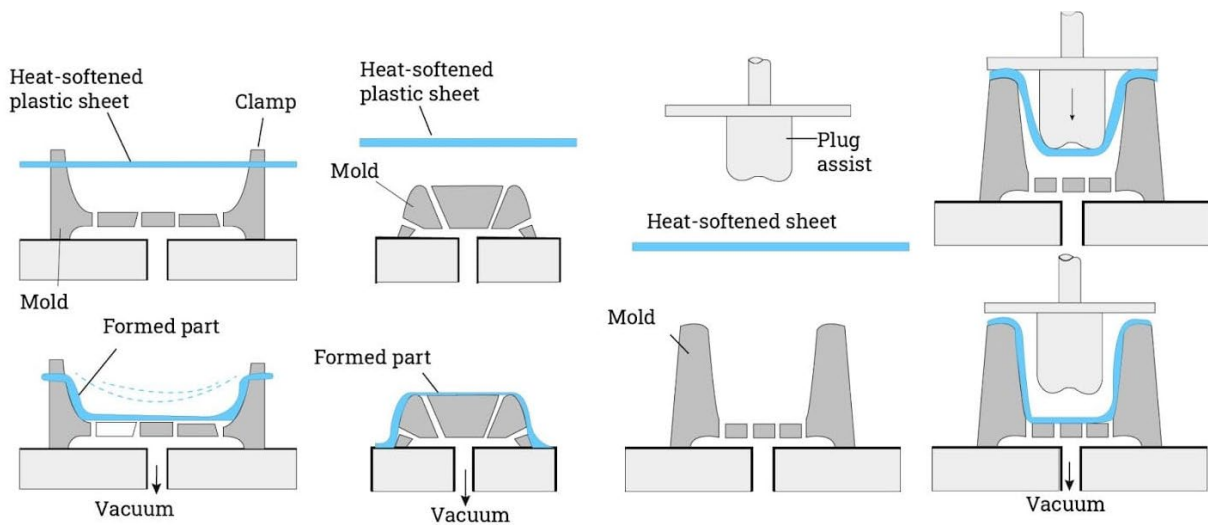

Figure 13 Four Vacuum (thermoforming) moulding techniques<sup>15</sup>.

<sup>15</sup> Image from iqsdirectory.com

**Table 22 Vacuum moulding characteristics.**

<p><b>Process</b></p>	<p>A heat-softened sheet is sandwiched in a mould (Figure 13). The air in the space between the sheet and mould is evacuated allowing atmospheric pressure to form the heated thermoplastic sheet into the desired shape to form products such as cups and trays. This process creates products with high definition while also limiting uneven thinning of the plastic sheet. After the form is achieved, the product is cooled to fix the product into its final shape. Common vacuum forming processes are listed in Table 23.</p>
<p><b>Skills required</b></p>	<p><b>Basic to Intermediate:</b> Vacuum moulding equipment is relatively simple and straightforward but may become more complex depending on the processing technique (as seen in Table 23). Achieving consistent results with recycled plastics may require moderate expertise. Operators need a basic understanding of the vacuum moulding process, including mould preparation, material loading, and operating the vacuum forming machine. While some technical knowledge is required, vacuum moulding is generally simpler compared to extrusion and injection moulding.</p>
<p><b>Suitability for micro-small enterprise</b></p>	<p><b>High:</b> It is cost-effective (relatively low initial investment), broadly accessible, and scalable making it well-suited for micro and small enterprises. Minimal investment in equipment and training means smaller businesses can use vacuum moulding for prototyping, small-scale production, or custom manufacturing, making it a viable option for those with limited resources.</p>
<p><b>Throughput</b></p>	<p>Range: &lt;1 to &gt;100 kg/hr Limiting Factors: Material heating and softening, and vacuum pressure and forming time.</p>
<p><b>Plastic types</b></p>	<p>Polyethylene (PE), polystyrene (PS), Polypropylene (PP), acrylic (PMMA), Polyvinyl Chloride (PVC), and Polystyrene (PS).</p>
<p><b>Example products</b></p>	<p>Plastic packaging that is fitted to a product’s design. Fruit containers, plastic egg cartons, cracker trays, blister packaging, children’s toys, travel accessories, home decor, hard-case luggage, bathtubs, industrial covers.</p>

**Table 23 Common vacuum forming techniques<sup>16</sup>.**

Techniques	Complexity	Suitability for Using Recycled Plastic	Justification
<p>Drape forming is the process for larger moulding applications and for those which do not require fine detailing (e.g., bathtubs, industrial covers, etc). The plastic sheet is heated until it drapes onto a mould under its own weight and a vacuum is applied to ensure a tight fit against the mould. This process can handle thicker plastic sheets than single- or double-sheet moulding.</p>	Low	High	<p>The process simplicity allows for easier processing of recycled materials, especially thicker plastic sheets, without compromising the quality or performance of the final product.</p>
<p>A single sheet of thermoplastic is heated until pliable, stretched over the mould and a vacuum applied to stretch the sheet over the mould and set. This simple design process is frequently used to manufacture simple parts like trays or blister packaging.</p>	Low	Moderate	<p>The process simplicity can accommodate recycled materials to some extent, especially for applications like trays or blister packaging where the structural demands might not be overly strict. However, the quality and performance of the final product may vary depending on the purity and properties of the recycled plastic.</p>
<p>Double-sheet is the same as the single-sheet process, however, two sheets of thermoplastic are heated until pliable and then simultaneously applied to a vacuum mould where one sheet is placed above and the other beneath the mould. This produces a product with two formed surfaces commonly required in products that demand greater detail and strength such as double-sided signs (where one sheet forms the interior and the other</p>	Moderate	Moderate	<p>This process can also be moderately suitable for using recycled plastic, as it's capable of producing products with greater detail and strength. However, the complexity of the process may introduce challenges in effectively incorporating recycled materials while maintaining the desired quality and integrity of the final product.</p>

<sup>16</sup> La-Plastic, 2023

Techniques	Complexity	Suitability for Using Recycled Plastic	Justification
<p>forms the exterior) or hollow objects. Due to precision and alignment requirements this process is more complex and expensive than single-sheet.</p>			
<p>In the Snap-back process the plastic is heated beyond the typical temperatures for thermoforming. The extra soft plastic is placed above the mould and the vacuum is applied. As the plastic slowly cools, the plastic 'snaps-back' and takes the desired shape. This produces a specialised product, which typically requires specific additional equipment for pre-stretching, that features sharper corners and finer detail appropriate for the intricacies of complex textures or logos, as used in the automotive industry.</p>	High	Low	<p>The precision required for sharper corners and finer detail makes it difficult to achieve consistent results with recycled materials, which may not possess the required properties for such intricate shaping. Additionally, the specialised nature of the products produced through this process may demand higher material purity and quality standards.</p>
<p>Pressure bubble plug assist forming combines pressure and vacuum techniques. A pressure bubble initially pushes the heated plastic sheet up, then a plug pushes the bubble downward into the mould and the vacuum is applied. This process is a very precise and advanced method and, if desired, can introduce intentional thickness variations for applications with uneven wall thickness requirements.</p>	High	Low	<p>The complexity of this process, a combination of pressure and vacuum techniques to achieve precise results, may pose challenges in effectively incorporating recycled materials. This process usually demands higher material purity for consistent material properties throughout the forming process and may be very challenging with recycled materials.</p>

### 3.3 Remanufactured Commodities

As first introduced in Table 2, there is the potential for plastic waste to be remanufactured into different products ranging from artwork to pipes or furniture. There are different price points associated with these products which will have an impact on their economic viability.

As discussed in 2.4, chemical treatment options are unlikely to be economically viable in the region despite the economic value of waste-to-energy treatment products like pyrolytic oil being greater than the products generated from mechanical treatment.

#### Case Study 1. Shredded, Granulated, and Pelletised Plastics

##### Fiji Mission Pacific Granulator

In 2022 Mission Pacific collected and shipped 140 tonnes of PET internationally for recycling in the form of bales. In mid 2023, as part of its commitment to increase the amount of PET plastic bottles that are recycled, Coca-Cola in Fiji purchased a granulator to turn the bottles into plastic flake at the Coca-Cola Europacific Partners Fiji's (CCEPF) factory site in Suva, the same place where the bottle buyback scheme Mission Pacific operates (FJ 5c per bottle if returned to one of the bottle buy-back centres, and 2.5c if pickup is arranged by the program).

##### Current status and development

Currently, Mission Pacific's buy-back system will accept any PET bottle but only Coca-Cola owned brands<sup>17</sup> are given a refund. Due to the improved volume reduction capacity from the granulator (previously bottles were baled) there is a greater capacity to collect and process more bottles which reduces the overall cost per tonne of materials exported. Pilots are underway in collaboration with CCEPF's sister company Paradise Beverages on the home collection of PET bottles. Efforts are focused increasing the number of collection points for people to bring their bottle back to using mobile caravans and pop up tents at parks and events.

##### Conditions for success

The system requires:

- CAPEX internally borne
- OPEX internally borne
- In-house technical expertise
- Social marketing team and campaigns
- Internal motivation drivers (EPR)
- Convenient and accessible collection points
- Incentives for bottle return (5c per bottle – Coca-Cola and partner brands only)
- Knowledge of international plastics market to secure the best price for granulated PET

---

<sup>17</sup> Coca-Cola Europacific Partners (Fiji) Ltd, Natural Waters of Viti Ltd, and the Motibhai Group of Companies: ji Water, Coca-Cola, Diet Coca-Cola, Coca-Cola Zero Sugar, Sprite, the Fanta Range, the Schweppes range, the Minute Maid Pulpy range, the Jucy range, the Frubu range, Mother range, Powerade range, Pure Drop, and the Sprint range (Mission Pacific, 2024)

## Suitability for Small Scale Plastic Processing in the Pacific

Moderate to High

- ↑ Reduces volume of export/Reduces cost of shipping per tonne
- ↑ Increases value of output
- ↑ Is a circular outcome
- ↑ Reduces pollution/landfill consumption
- ↑ Incentivises collection
- Moderate level technical expertise
- Requires large parcel of land for cleaning, processing, and storage
- ↓ High level of knowledge of international plastics market required to get good prices
- ↓ CAPEX and OPEX internally borne

### **Samoa Recycling and Waste Management Association (SRWMA) pelletiser (Marina Keil president of SRWMA)**

In 2021, SRWMA, a non-profit organisation in Samoa, began plastic recycling operations. SRWMA was granted a total of WST \$477,097 (equivalent to USD 190,123) through Japan's Grant Assistance for Grass-Roots Human Security Projects (G.G.P) for the development of plastic recycling in Samoa. J-PRISM assisted in preparing the application documents, providing cost support for architectural design, planning the pilot project implementation on plastics, and coordinating with other donors for the construction of this recycling facility. They collect plastic waste from 55 locations on Upolu in communities, schools, supermarkets, hotels, sporting venues, and government buildings. PET and HDPE plastic is separated in cages and processed at their recycling plant by a pelletising machine. Plastic bottles are cleaned, de-capped, and sorted by volunteers and local empowerment groups (Senese – a women's equal opportunities entity), compacted into bales, and exported to larger recycling plants in Australia. The recycling cages were donated by the Coca-Cola Foundation and the New Zealand High Commission (20 cages and awareness raising - WST \$43,000).

### Current status and development

In 2022, SRWMA and J-PRISM II started the next stage of their plastic recycling pilot project to advance plastic recycling (in the pipeline since 2020). This initiative now partners with the Samoa Ministry of Natural Resources and Environment (MNRE) and the Secretariat of the Pacific Regional Environment Programme (SPREP). The advanced plastic recycling stage includes a crushing machine and extruder (pelletiser) and were imported from Japan to Samoa and have been operating since July 2022. JICA spent 6 months selecting, tendering and procuring the crusher (~10mm flake at 50-100kg/hr) and extruder machines (5mm pellet at 15kg/hr). The "Made in Samoa pellets" will be sold to plastic recyclers and buyers at international markets (having successfully pelletised PET and ABS). Alternative products considered are construction items like 100% recycled plastic bricks but face a longer pathway commercial quality and quantity production. Capital costs<sup>18</sup> for SRMWA plastic recycling facility:

- Facility (3,008m<sup>3</sup>): constructed by GGP, Embassy of Japan (WST \$477,097)
- Machine: provided by J-PRISM II (crushing machine: WST \$25,922, extruder: WST \$59,166)

---

<sup>18</sup> J-PRISM II, 2023

- Equipment and tools for facility: provided by J-PRISM II

Ongoing costs such as labour, electricity and water for implementing the pilot project were covered by SRWMA.

### Conditions for success

The following are externally provided:

- Capital costs investment for machinery
- Training for operation and maintenance
- Continued multi-year technical support
- Continued multi-year maintenance support
- Continued multi-year support from donors to hire workers
- Continued multi-year guidance from crushing and extruder machine manufacturers for strengthening of local maintenance and management systems
- Continued multi-year support for prototyping of moulds, improvement of mould design, mass production.

Additionally, the system requires:

- Reliable customers (recyclers, buyers, etc.)
- Strong community engagement, awareness raising, and training (multi staged approaches)
- Strong multi-partnership design (in this case, JICA, SRWMA, MNRE and SPREP)
- Stable number of workers
- Establish a support network of plastic manufacturers and recyclers for receiving professional guidance on selecting plastic raw materials, moulding products, and developing recycled plastic products.
- Plastic waste is donated (obtained free of charge)

### Suitability for Small Scale Plastic Processing in the Pacific

Moderate to High – For some PICs, if supported the same degree or greater, this may be achievable (in limited capacity) but the sustainability is uncertain.

- ↑ Produces several marketable recycled plastic outputs
- ↑ Reduces volume of export/Reduces cost of shipping per tonne
- ↑ Increases value of output to an advanced market
- ↑ Reduces pollution/landfill consumption
- ↑ Is a circular outcome
- Requires external funding for procurement
- Requires large parcel of land for cleaning, processing, and storage
- ↓ High level technical expertise
- ↓ Requires a stable number of workers

## Case Study 1 Conclusions:

Donor projects, such as Samoa's SRWMA plastic recycling programme, heavily rely on the financial and technical capabilities of the donor organisation, have high staff turnover rates, or both. As a result, the sustainability of the operation is typically uncertain once the project comes to an end as knowledge is lost, and momentum drops off. A focus on local training centres as the repository of recycling skills knowledge and transfer should be prioritised to enable a self-sustaining system.

Some countries, like Kiribati and Palau, which have Container Deposit Legislation (CDL) to support the flow of plastics exist due to external donor support and have generated a deposit fee value for plastics to incentivise their collection. Fiji's Mission Pacific adopts an Extended Producer Responsibility (EPR) approach to its buyback system, akin to a private venture CDL. Without a value attributed to the recyclable (CDL) or without external funding (Donor), plastic collection does not occur on a commercial scale. Thus, the public is not incentivised to recycle plastic and will focus on more lucrative recyclables (e.g., metals).

In the Pacific, even when Moana Taka is applicable, the lack of an external subsidy support system means that many plastic recycling initiatives are not financially viable.

## Case Study 2: Recycled Content in Plastic Products

### Samoa Plastic Outdoor Furniture (Plastic Waste Free Islands)

In 2021, Under the IUCN Plastic Waste Free Islands project for Samoa a business plan for waste-to-product was developed. Its aim was to target post-consumer HDPE, PP, and LDPE through a whole-of-system value chain to produce mixed extrusion products from plastic waste. The waste-to-product output for this concept is outdoor furniture for use in gardens, parks, wharfs, and other outdoor public spaces. For high end products, HDPE is sorted and washed. For lower end product, mixed unwashed plastics can be used with at no less than 70% PE/PP by weight.

This approach uses a shredder and/or agglomerator, an extruder, a press and moulds, intrusion moulds, or a continuous extrusion line.

**Table 24 Machine Costs**

Machine	Costs
<b>Shredder</b>	USD 5,000 (additional USD 25,000 for shredder with washer)
<b>Extruder</b>	USD 15,000
<b>Intrusion mould</b>	USD 10,000
<b>Press</b>	USD 7,000
<b>Plank moulds x 2</b>	USD 7,500

### Current status and development

A full Market introduction plan was developed and includes three phases and once operation is in effect, the simplified financials predict a 30 month payback period of a USD 180,000 investment:



**Table 25 Planned stages for business plan**

PHASE 1- has been completed	PHASE 2	PHASE 3
<ul style="list-style-type: none"> <li>• Extrusion testing</li> <li>• Feedstock preparations</li> <li>• Product interest inventory</li> <li>• Design concept for products.</li> <li>• Engineering</li> <li>• Prototyping                             <ul style="list-style-type: none"> <li>• assembly testing</li> <li>• impression and use testing.</li> </ul> </li> <li>• Improving based on feedback</li> </ul>	<ul style="list-style-type: none"> <li>• Securing finances; procurement of machinery; staff recruitment</li> </ul>	<ul style="list-style-type: none"> <li>• Production testing</li> <li>• Production procedures development</li> <li>• Packaging development</li> <li>• Commercial production based on staged approach.</li> </ul>

### Conditions for success

The following expected to be externally provided:

- Capital costs investment (Development Bank loans, Investors/business accelerators, government grants)
- Training for operation, maintenance, and mould design
- Affordable and available land

Additionally, the system requires:

- Waste is segregated and obtained through donation (no purchasing of waste) and at the cost/effort of the contributor
- 7-10 FTE staff (sales, technical, admin, transport)
- Collaborators (retailers, tourism sector, government, donors)
- Reliable customers (recyclers, buyers, etc.)
- Willingness to purchase recycled plastic furniture made from own waste
- Willingness to source-segregate recyclables

### Suitability for Small Scale Plastic Processing in the Pacific

Moderate

- ↑ Produces several marketable recycled plastic outputs
- ↑ Recycles into the local economy
- ↑ Reduces landfill consumption
- ↑ Increases value of output to an advanced market
- Scalable from small business (not micro)
- Requires a medium parcel of land for cleaning, processing, and storage
- Partially circular outcome (poor future recyclability of mixed wastes products)
- Moderate technical expertise across several skill sets for machinery and product design
- ↓ Requires high external funding to procure the system

## Precious Plastic Fiji moulded product

Precious Plastic designs and develops machines aimed at recycling plastic. Once the machines are completed, they openly share the instructions on how to replicate them with the world at no cost. This approach is intended to contribute towards addressing the issue of plastic waste by enabling more widespread adoption of plastic recycling solutions.

### Current status and development

Precious Plastic Ambassador Raeed Ali brought Precious Plastic to Fiji to tackle the surplus of plastic. NICEF's WASH program has collaborated with Raeed to launch a network of Precious Plastic hubs in Fiji. Funded by UNICEF, Raeed has effectively established upcycling and recycling centres in Suva and delivered plastic recycling education to over 50,000 Fijian students. These centres serve as convenient drop-off locations for the local community, promoting sustainable waste management practices and environmental conservation. Through this initiative, 30 tonnes of plastic have been processed, with over 10 tonnes diverted from landfills since 2018. The centres in Suva shred, melt, and compress plastic waste into bricks (moulds acquired from India). Machines from precious plastic costs come in two forms: Basic (educational or demonstrational) and Pro (semi-industrial machines).

**Table 26 Precious Plastic Machine Costs**

Machine	Basic	Pro
<b>Shredder</b>	Single axe   EURO 1,100	Double shaft   EURO 2,200+motor   50kg/hr
<b>Extruder</b>	Single screw   EURO 1,200	Single screw   EURO 2,000   20 kg/hr <sup>19</sup>
<b>Hand powered injection</b>	EURO 350	-
<b>Car jack compressor</b>	EURO 200	-
<b>Sheet press</b>	-	Hydraulic press   EURO 2,500   20 kg/sheet <sup>20</sup>

In addition to his work with Precious Plastic, Raeed has co-founded the Alliance for Future Generation (AFG), Fiji's prominent youth-led network dedicated to sustainable development. With a membership of 500 individuals, AFG takes a systemic approach to tackle complex challenges like plastic waste management. AFG members actively participate in environmental conservation efforts within local communities and villages, aiming to transform the discourse and drive significant change by leveraging collective knowledge and resources.

### Conditions for success

The system requires:

- External funding and donor support
- Open source approach to technology with an active online collaboration/support community
- Technology is much smaller, modular, and more attainable than commercial counterparts.
- Education and community engagement
- Sustainable source of material

<sup>19</sup> productions of beams or bricks

<sup>20</sup> multiple sheets (1x1 meters) per day

## Suitability for Small Scale Plastic Processing in the Pacific

High

- ↑ Produces several marketable recycled plastic outputs
- ↑ Scalable between micro and small business
- ↑ CAPEX less exclusionary than commercial scale machinery
- ↑ Recycles into the local economy.
- ↑ Designed to be maintainable for developing countries
- ↑ Online community support and resources for knowledge sharing and troubleshooting (lower technical skills required)
- ➔ Requires small to medium parcel of land for cleaning, processing, and storage

### Case Study 2 Conclusions:

Donor projects, such as both the IUCN supported PWFI and UNICEF Precious plastic recycling programme, heavily rely on the financial and technical capabilities of the donor organisation. As a result, the sustainability of the operation is typically uncertain once the project comes to an end as knowledge is lost, and momentum drops off. A focus on local training centres as the repository of recycling skills knowledge and transfer should be prioritised to enable a self-sustaining system.

Neither the PWFI nor the Precious Plastic project have first conducted a business case to consider if the products being produced were something that the local market wanted or would be willing to pay sufficient funds to sustain the recycling project post project. In both cases securing feedstock has relied on free collection, and it is noted that the volumes collected are very small compared to actual volumes present.

In both cases the products produced are also not particularly circular at this time and may represent a linear recycling project. In the case of the PWFI plastic lumber projects the recyclers who conducted the recycling were not convinced it was viable or would progress once donor funding ceased. These two plastic recycling technologies appear to be at the boutique or hobbyist end.

### Case Study 3: Energy Recovery

#### Palau's Koror State Government Energy Recovery Facility

Palau's Koror State Government Energy Recovery Facility operates continuous extraction of 1,000 litre of oil from 1,000kg of plastic per 24 hours and accepts polypropylene (PP) and polyethylene (PE) wastes (JICA, 2016). The Koror State Government website specifies that the convertible types of plastic wastes include bottle caps and wrappings, butane caps, plastic bags, candy bar wrappings, bleach containers and caps.

The fuel generated by the process feeds back into the facilities for uses such as electricity generation, boiler operation, and fuel extender. The system, however, primarily uses the extracted plastic oil to generate electricity in a DCA-300ESK generator to in return operate the pyrolysis system itself in a self-sustaining loop. Simply put, there is no net energy output; It produces enough energy to run itself.

## Current status and development

The Energy Recovery Facility is still operating in 2024, however, the CBA previously shared by JICA shows that while this is technically interesting it does not have a viable business case, because as indicated above, there is no net energy output. The technology was provided by JICA who also supports its ongoing maintenance.

## Conditions for success

The following are externally provided:

- Capital costs investment for machinery
- Training for operation and maintenance
- Continued multi-year technical support
- Continued multi-year maintenance support
- Support for monitoring and verification

Additionally, the system requires:

- Establish a segregation system – Palau obtained segregated plastic waste materials through donation (no purchasing of waste) and at the cost of the contributor.
- Affordable and available land

## Suitability for Small Scale Plastic Processing in the Pacific

Low

- ↑ Reduces landfill consumption
- Requires external fund for procuring it
- ↓ High level technical expertise
- ↓ No net product produced
- ↓ Produces GHG and other harmful emissions through combustion of plastic derived fuel
- ↓ Use of plastic derived fuel may void warranty on the generator
- ↓ Not circular

## Solomon Islands NuFuel Micro Pyrolysis

In the Solomon Islands there is a micro-scale pyrolysis technology developed under a NZAID project using Nufuels technology (a New Zealand Company) in at least 2 communities focused on converting waste plastic bags and bottles into energy (SPREP, 2021) and rolling out to 3 more under UN Small Project Fund initiative to be deployed to St Martin's Rural Training Centre Honiara, Kaotave Rural Training Centre, Guadalcanal, and to St Peter's Rural Training Centre, Gizo, Western Province including the Plasticwise Gizo group (NuFuels, 2024). The resulting oil, comparable to diesel, is used to fuel 'rocket stove' systems for baking and drying, while the gas is harnessed for cooking and powering petrol gensets. The feedstock is confined to plastic bags/film and bottles to prevent the production of hazardous by-products during pyrolysis. It can utilise around 7kg of waste per cycle to produce 5kgs of a viscous plastic crude and 2kgs of gas. It is a very simple operation, but has been developed, implemented and run by Solomon Islands citizens.

## Current status and development

Expansion in Melanesia has been delayed by COVID, but NuFuels note on their website that they have been awarded a contract by UNDP and have started further roll out. With the new single use plastic ban introduced

into the Solomon Islands in late 2023, and now in effective in 2024, the feedstock items for this initiative will be reduced over time. The initiative also targets PET bottles, which are valuable recyclables and can be returned into a circular system rather than used as another source of fossil fuel. Utilisation of plastic derived fuels in generators is likely to void their warranty.

#### Conditions for success

The following are externally provided:

- Capital costs investment
- Operational training to extract the energy from plastic waste

Additionally, the system requires:

- Affordable and available land
- Willingness of local communities to adopt the system
- Partnership with local entities (e.g., Solomon Airlines) for local by-in
- Knowledge transfer
- Sustainable source of material

#### Suitability for Small Scale Plastic Processing in the Pacific

Low:

- ➔ Reduces landfill consumption (but in small volumes)
- ➔ Funding for ongoing operations needed
- ➔ Moderate technical expertise required
- ⬇ Produces GHG and other harmful emissions through combustion of plastic derived fuel
- ⬇ Use of plastic derived fuel may void warranty on the generator
- ⬇ Plastic bag feedstock required for this technology will be reduce due to Solomon Islands SUP ban
- ⬇ Diverts efforts away from developing a PET recycling system (also HDPE and PP)
- ⬇ Not circular

#### Case Study 3 Conclusions:

Neither of the 'waste to energy' pilots covered above actually represent plastic recycling, instead plastic wastes are basically combusted in two stage processes that first convert them from plastic polymers back into 'plastic derived fuels. These fuels are then combusted in generators in the same way that other fossil fuels would be, such as fuel oil or diesel. This is a linear waste management process with atmospheric disposal of GHG derived from second hand fossil fuels.

In the case of the Palau system no net energy is produced, just enough plastic derived fuel to run the process to produce the fuel for the next run. In the case of the NuFuel process, net energy is produced but the feedstock is based on recyclable PET plastic bottles which have a higher value as a recyclable and on SUP plastic bags that are subject to bans. NuFuel is also aimed at remote communities in the Solomon Islands which normally have an abundance of biomass, so it is unclear if NuFuel serves an actual need in the community or is built around being primarily a waste management tool.

Like Case Study 1 and 2 the two Case Studies above depend on donor finance without a clear business case or ability to continue without donor funding.

## 3.4 Challenges to Plastics Recycling

### Incompatibility in Recycling

The different plastic types are incompatible for recycling together. For example, small amounts of PVC will destroy the polymetric properties of PET. When different plastics are melted and remoulded, they tend to separate and lose structural integrity.

### Declining Plastic Quality

Plastic materials get degraded in quality each time they go through the heating and recycling process. At a certain point, the plastic becomes too degraded to recycle again (Yao et al., 2013). These inherent technical challenges get compounded by how plastic waste is typically collected. Households and businesses usually lump all plastic waste together in one bin, including contamination from food residues. This requires a labour intensive sorting process later to separate out the different plastic types.

### Markets for Recycled Plastic Products

With recycled plastic selling for relatively low prices, recycling operations face diminishing returns the more cycles the plastic goes through. The remote island locations make transportation and finding buyers more costly. Many Pacific countries lack policies that discourage single-use plastics and encourage sustainable alternatives. The islands also import far more plastic products than they produce locally.

There is limited data on the estimated figures of globally recycled plastics. Current estimates range from 9% to 12% (Geyer et al., 2017; OECD, 2018).

# 4 Stakeholder Engagement

In this chapter, a summary of the stakeholder analysis is prepared. The stakeholder engagement process is described in detail in Appendix A.

The purpose of the stakeholder engagement process is to supplement the information from the literature review as well as to get a better understanding of the human capital requirements, gender and social equity, and sustainability concerns from these technologies.

## 4.1 Stakeholder Engagement

Stakeholders have been engaged across PICs and efforts were undertaken to ensure that a diverse range of perspectives from different organisations were considered across the three subregions of Melanesia, Micronesia, and Polynesia.

This engagement focused on input in identifying suitable small scale plastic recycling technologies (to process plastic wastes) to individual country context and what mechanisms would be needed to sustain them (operations, feedstock management, product demand, finances).

While a very broad range of individuals were invited to be involved (as shown in Table 1 of Annex A) particular attention has been focused on those most directly interested, involved and necessary to enable small scale plastic recycling to operate. Understandably those most involved already, impacted by SUP plastic management or likely to be impacted were the most responsive.

The team also referred to several other stakeholder engagement notes from consultancies recently undertaken in the Pacific or still underway. Below is a summary of issues raised, discussed and of relevance to those stakeholders and this assignment.

### Local Community

This engagement focused on input in identifying suitable small scale plastic recycling technologies (to process plastic wastes) to individual country context and what mechanisms would be needed to sustain them (operations, feedstock management, product demand, finances).

Local community interest in relation to small scale plastic recycling coalesced around the desire to:

- be formally consulted on what the impacts and benefits would be. This includes addressing what the technology will do and the degree to which they can stay informed through websites, presentations and other sources of periodic and permanent information.
- be advised if there would be any risks or impacts. This includes ensuring regulation and plans safeguard against processing locations becoming dumpsites and that their local communities are kept clean and neat without odour or visual impacts.
- be informed on how these technologies will assist in amenity of their communities through cleaning up plastic wastes currently mismanaged (i.e., through burning, burying, littering or disposal - dumpsite or into the environment including the ocean).

- be informed on what opportunities this would offer to improve livelihoods. Furthermore, can this be considered in operationalising such technology through 'buybacks' of plastics by the private sector (Coca Cola Mission Pacific) or container deposit/advanced recycling fee.

- be informed whether there would be new jobs created in their communities, including training and job development. Can this be built into any application of new processing technologies?

Local communities, while they are very diverse across the Pacific, are supportive of such recycling proposals but shared frustration in the lack of consistent and ongoing sources of information and were sceptical of the impact and sustainability of plastic recycling as they have experienced minimal progress to date. As expected, communities with options to collect and return plastic bottles (Kiribati, Palau, RMI, Parts of FSM, partly Fiji (Coca Cola) are enthusiastic about these schemes, but this experience is not shared by the majority of the Pacific where there are no such schemes.

## Business and Industry

Stakeholders in business and industry included those who import products that generate plastic wastes, those who produce plastics within the Pacific through imported precursor materials (national water bottling companies), retailers, and then those managing wastes and/or recyclables. From stakeholder reviews it is clear that plastic recycling is of great interest, so technologies that could improve the recycling environment by making value added products with a better prospect of being exported or utilised in countries or the region would be a benefit.

The pressure placed on plastic importers, creators, users (through the steady impact of SUP bans, plastic levies and increased expectations that SUPs should be eliminated or recycled) is increasing from a very low level of activity in the Pacific.

Coca Cola, through its Mission Pacific project, is the only known business that supports plastic buyback, albeit only in Fiji for its branded PET bottles and to a much lesser degree in Samoa. However, it has not translated this strategically from collection and export of PET bales until recently. Coca Cola is now engaged in a PET granulation pilot with Fiji based recyclers.

Punjas in Fiji has shown a strong interest in plastic alternatives and recycling and is seeking competent bodies to engage with. As an example of its commitment, it has made a biodegradable/edible drinking straw used in the Fiji Touristic centres made from locally produced tapioca and sugar cane wastes.

Vanuatu beverages has an interest in recycling system or even to transition to non-plastic, but most national PET water bottlers are unresponsive and exhibit little interest. Many prominent international companies like the Wonderful Company (owner of Fiji Water), are not transparent about their environmental practices. Importers of plastic films (including LDPE), HDPE, PP, and other plastic packaging materials are currently not participating in recycling initiatives, despite showing interest.

A review of recyclers has found that export of plastic has been minimal and has only involved baled PET when it has happened. In all cases this has been subsidised, either by the private sector, a donor funded project, or more sustainably via a CDL/ARF system. Recycling and reprocessing of SUPs has occurred and is occurring in Fiji, Samoa, Palau and the Solomon Islands in small pilot scale technology applications but have not yet translated into a sustained business. Although, it was found that PET granulation in Fiji (supported by Coca Cola) and separately the production of moulded products from plastic wastes is occurring (discussed further in the 'Case Study' section).



Sustained recycling of plastic in the Pacific for PP, HDPE and LDPE does not occur if there is no subsidy, unlike for PET. When there has been an active subsidy, export has only sometimes occurred as some countries still lack the understanding of international markets (Kiribati, Palau, Tuvalu) and fail to export even baled plastics.

Business and industry in the Pacific would be interested in being part of a plan with strategic funding and technical know-how and market knowledge to best transition to a lower SUP environment with greater circularity of materials needed for their business.

Recyclers have a great interest but also need assistance with government (CDL/ARF/Levy) or industry frameworks (EPR) to build sustainable recycling systems on par with profitable non-ferrous wastes. They also need access to grant and/or low interest loans, infrastructure and land, technical and market expertise to transition to plastic recycling and value adding.

Recyclers also complain of significant barriers from governments where, for example, exemption requests are denied on 40% import/customs levies placed on plastic recycling equipment, or situations where taxes are even being applied on top of shipping fees, or the lack of access to land to conduct recycling operations. Governments have a wide range of incentives they are typically able to give, but often these go to lucrative areas of logging, fisheries, mining or land development.

Recyclers also complained that they are essentially unsupported in most cases by donors where resources that are allocated for 'waste management' are channelled into local or national government entities. They noted that the only donor entity trying to address this is JICA through creating, funding and equipping Waste Associations.

Another critical business stakeholder are the shipping agencies with the Moana Taka program. Although a ground-breaking initiative, it is underutilised. Swire Shipping has expressed its added interest on expanding its role within this sector, where it already plays an important component for plastic wastes in the Pacific for 8 or 9 of the 13 PICs. Thus far, it has enabled PET bales to be exported from Fiji even in the absence of a CDL system.

## Government

There are no government stakeholders that express anything but enthusiasm for plastic recycling, however analysis of stakeholder comments, levels of interest and engagement by governments and commitment though actions were found to vary widely from government to government.

Government ownership of the issue was discussed as being very important with the example of Minister Reganvanu having progressed two successful SUP bans in Vanuatu. Despite this, with his departure the new government has failed to establish a Vanuatu CDL legislation or action the draft National Vanuatu Plastics Strategy since its development 6 years ago (it remains a draft to this day).

What is clear is that Government engagement is an essential component to the success of plastic recycling in the Pacific as the sustainability frameworks for long term plastic recycling. As identified by Pacific recyclers, this is integral to progress beyond donor or industry supported projects by providing the necessary subsidies to close the gap between the costs of recycling plastics and the mostly negative profits.

Governments are, however, providing support through requests to bilateral and multilateral donors, including investment banks. While governments stakeholders accurately advise that these follow their national plans,

strategies, acts, regulations and such, these frameworks are often crafted for a different purpose and do not translate into supporting new recycling with systems, frameworks, infrastructure and equipment requests.

Pacific Governments are interested in support from the regional technical support organisations, the private sector, donors and investment banks to fill the gaps and help develop coherent, responsive and funded plans for plastic recycling in addition to other waste management improvements.

Governments are also the pathway for donor and investment bank resourcing for areas like SUP recycling, but need to commit to developing frameworks, plans and policies that can direct such aid to grow the plastic recycling sector.

## Donors

From a discussion with donors, support in SUP management both by itself and as a subset of waste management is a hot topic and is supported with a variety of regional and bilateral projects, investment grants and loans, technical training, business support activities. In most cases, however, donors need clear invitations from Governments to engage. Generally, this translates to support being provided to government and not to the private sector.

Furthermore, donors experience problems with gaps and overlaps between projects and are challenged in determining what assistance is most needed in the Pacific context, what to provide to the countries, and how to provide it. It was observed that donor connectivity with the admittedly small recycling sector was quite poor.

Donors need coherent plans to assist in developing well supported plastic recycling programmes and a clear and sustained commitment from the government. It is observed that when this occurs good systems are created, as it has with establishment of CDL and prepaid bag in Kiribati.

Donors are critical to this equation and there are few improvements to waste and plastic management systems in the Pacific that are not the result of donor funded projects. But donors acknowledge a need for an improved capability to connect with the private sector and JICA has provided one model on how this can be achieved.

## Interest Groups

There were a wide range of other interest groups that were engaged at the national, regional and international level. In general, their interest intersected within the scope of their organisation. While many of these comments, concerns and queries overlapped with those already discussed above several additional areas of discussion were raised.

The first related to the specific engagement of women, youth, those with a disability and waste pickers (essential for recyclable collection in much of the Pacific). They expressed interest in being integrated into the development of new plastics recycling projects for any proposed recycling solution/operation in their communities.

Environmentally focused entities were concerned about any plastic recycling that involved GHG emission to atmosphere, burning of plastics (creating dioxins and similar subject to the Stockholm Conventions), release of microplastics to the environment or only linear recycling of plastics (downcycling, creation of further 'one time' use products). Such groups were enthusiastic about plastic technologies that would incentivise collection of

plastics currently lost to the environment, the creation of circular economy-based recycling, and protection of the marine ecosystems.

## 4.2 Specific GEDSI Considerations

From a gender lens, women often bear a greater burden when it comes to managing household waste and cleaning up the environment. They also often face challenges in accessing information and resources, and in participating in decision-making processes. Regarding cultural expectations around gender roles (e.g., motherhood, caretaking responsibilities), women may, despite their level of interest, face barriers in accessing training and employment opportunities related to operating and maintaining recycling technologies. Additionally, under manual sorting scenarios, there is a concern that for new operations the labour required for sorting, cleaning, and preparing recyclables may fall disproportionately on women, adding to their domestic responsibilities.

Ensuring women's voices are heard and their needs are addressed is essential to the success of any potential recycling and product distribution system. Providing opportunities beyond immediate solutions (e.g., creches at workplace or training facilities – a positive first step) will be necessary to a sustainably integrated approach where subtle but more deeply engrained cultural phenomena, that are poorly documented by western literature (e.g., wantok), require a systematic paradigm shift to accommodate the desired outcomes.

PICs are, with variation, patriarchal societies and follow traditional socio-cultural systems of Kastom (Pijin for 'custom' which are village specific traditions and practices passed down through generations) and Wantok (Pijin for 'one talk'). In Melanesia, wantok is an important part of village ties and describes a communal duty of care within groups of people who speak the same language or come from the same village/area. Under wantok group members are expected to provide support (including basic needs and other financial support) to one another.

However, despite being a well-established part of cultural life for many Melanesians, it has been reported anecdotally that the wantok system causes some issues not just in private endeavours but in government/public sector working contexts too. This can create vulnerabilities to the economic independence and sustainability of small businesses in the Pacific, regardless of the sex of the entrepreneur, but especially for women.

In terms of equity, the remoteness of some islands within PICs and therefore the disproportionate breadth and quality of resources and infrastructure means that some communities, particularly those in more isolated or disadvantaged areas (i.e., beyond the boundaries of capital cities), have limited access to services and markets. Thus, the location of recycling facilities could disadvantage certain communities, leading to uneven distribution of benefits and burdens. This can exacerbate existing disparities between communities, skewing the impact of programmes, funding and economic benefits to those living in more centralised/urban environments.

**Diversity:** As the Pacific region is made up of people with different cultural backgrounds, traditional practices, and perspectives on waste management. There is a desire for selective agency (i.e., the ability to engage with a solution that best meets their unique environment rather than a prescriptive model) to achieve a local solution. Embracing this diversity and incorporating traditional knowledge can lead to more holistic and culturally appropriate solutions.

From a social inclusion standpoint, engaging youth, the elderly, and marginalised groups in the development and implementation of plastic waste management strategies is essential. These groups often have unique insights and can play a vital role in driving change. However, there is a general concern that the potential job creation in a recycling network may not be equitably distributed, with certain groups (e.g., youth, ethnic minorities) facing barriers to employment due to discrimination.

Pacific Youth Council for example has been active in closing this gap for the past 10 years through targeted action on increasing young people's involvement in entrepreneurship, involving more young people in youth-led climate change monitoring and adaption programmes, and engaging more young people in promoting sustainable environmental practices.

Across all these dimensions, the key message was a greater degree of collaborative, inclusive, and equitable engagement that empowers all members of PIC communities to participate in finding solutions. This may involve targeted outreach, ongoing capacity-building and training, and the creation of platforms and networks for diverse voices to be heard.

# 5 Value Analysis of Potential Technologies to Remanufacturing Plastics

A high-level analysis of potential technologies to recycling plastics is conducted in this section.

The various technologies will be assessed based on the desktop research and insight gained from consultation. A multi-criteria analysis (MCA) framework will be used to undertake the assessment of potential technologies. A full description of the MCA process will be described in the Appendix B. The legend for the MCA is found in **Error! Not a valid bookmark self-reference..**

**Table 27 Legend for MCA**

LEGEND	
Score of <=2	
Score of between 2 and 3	
Score of 3 and 4	
Score of >=4	

## 5.1 Summary of MCA Results

The MCA analysed 8 potential technology options against four objectives and criteria (Table 38: Even-Weighting Assignment for Objectives and Criteria). Based on this analysis, pelletisers, granulators and shredders were the highest ranked largely due to their scoring in the technical suitability assessment. These are all stage 1 technologies that produce feedstock materials for further use. If there is a desired for that further use to be developed within or across PICs, pelletisers (or granulators) + extrusion moulders followed by pelletisers (or granulators) + injection moulders are the technology combinations that are recommended.

**Table 28 Priority Technology for PIC context**

Priority	Score	Technology Option	Stage
1	4.0	Granulator	1
2	4.0	Pelletiser	1
3	3.9	Shredder (single and dual)	1
4	3.5	Pelletiser + Extrusion Moulder	1&2
5	3.3	Pelletiser + Vacuum Moulder	1&2
6	3.3	Pelletiser + Injection Moulder	1&2
7	3.0	Pelletiser + Blow Moulder	1&2
8	2.9	Density Float + Washing and Drying + Pelletiser	1

## 5.2 Multi Criteria Analysis

The top performing technology option across the following criteria are:

- Supply and demand: Pelletiser
- Technical: Shredder
- Human Resources: 4 way tie – Shredder, Granulator, Pelletiser, Pelletiser + Vacuum moulder
- Sustainability: Granulator

**Table 29. Multi Criteria Analysis Results**

Spider Web	OBJECTIVES AND CRITERIA	WEIGHT	Shredder (single and dual)	Granulator	Density Float + Washing and Drying + Pelletiser	Pelletiser	Pelletiser + Extrusion Moulder	Pelletiser + Injection Moulder	Pelletiser + Blow Moulder	Pelletiser + Vacuum Moulder
Supply and Demand	Supply and Demand: To ensure there is sustainable supply and demand for the recycled commodity (domestic and internationally)	100%	3.50	4.00	3.50	4.50	4.00	4.00	2.50	3.00
	Ensure sustainable supply of waste input materials	50%	4.00	4.00	3.00	4.00	4.00	4.00	2.00	4.00
	Ensure sustainable demand for recycled commodity	50%	3.00	4.00	4.00	5.00	4.00	4.00	3.00	2.00
Technical Assessment	Technical: To ensure options are selected with the most robust and sustainable technical capability for the processing of recyclable plastic materials in the Pacific region.	100%	4.38	4.13	3.00	3.63	3.13	3.00	2.50	2.88
	Enhance the scale of technology for improved efficiency	25%	5.00	5.00	5.00	5.00	3.00	4.00	3.00	2.00
	Select technology that efficiently handles a variety of plastic wastes	25%	4.00	3.00	2.00	3.00	3.00	3.00	2.00	3.00
	Optimise site layout and design for operational sustainability	25%	4.50	4.50	2.50	3.50	3.50	3.00	3.00	4.00
	Optimise suitability for PICs use	25%	4.00	4.00	2.50	3.00	3.00	2.00	2.00	2.50
Human Capital	Human Resources: To ensure technologies have with the greatest positive social outcomes/impacts.	100%	3.50	3.50	2.50	3.50	3.00	2.00	3.00	3.50
	Optimise labour inputs for increased productivity	50%	3.00	4.00	3.00	4.00	3.00	2.00	3.00	3.00
	Enhance capacity through skills development and targeted training programs	50%	4.00	3.00	2.00	3.00	3.00	2.00	3.00	4.00
Sustainability	Sustainability: To drive the adoption of context specific technological solutions with long-term resilience.	100%	4.25	4.50	2.50	4.25	4.00	4.00	4.00	4.00
	Minimise external impacts associated with the technology	50%	5.00	5.00	3.00	5.00	5.00	5.00	5.00	5.00
	Optimise energy and water sustainable sourcing	50%	3.50	4.00	2.00	3.50	3.00	3.00	3.00	3.00

## 5.3 Cost-Benefit Analysis

Following the MCA, a simple cost-benefit analysis (CBA) is conducted to evaluate the potential economic gains from small-to-micro plastics enterprises adopting some of the preferred technologies to recycle plastics waste into commodities.

The cost-benefit analysis considers the long-term benefits and costs, all discounted to present value terms to enable the comparison of projects on a consistent basis. In this CBA, the two metrics that inform the prioritisation of projects will be the net present value (NPV), and the benefit-cost ratio (BCR).

The NPV is calculated as the present value of the life-cycle benefits less the life-cycle costs. Where the NPV is  $> \$0$ , the project provides net benefits to society. The project that provides the greatest net benefits is generally considered superior. Furthermore, the analysis of the distribution of the benefits provides insight into opportunities for co-investment.

The BCR is the ratio of the present value of the life-cycle benefits over the costs. For a project to be viable, the BCR must exceed 1, and the project with the highest BCR is considered superior.

### Scenario Definition

An economic analysis was conducted to assess different approaches to managing plastic waste. This analysis considered three options identified based on the results of a multi-criteria analysis (MCA). To evaluate these options, they are compared to a baseline scenario, which represents a situation with "business as usual" for plastic management policies. In other words, the baseline assumes no significant changes to plastic management policies, particularly those impacting micro and small-scale actors, throughout the evaluation period.

The three modelled options are summarised as follows: Stage 1: Plastic Feedstock Preparation Stage and Stage 2: Plastic Moulding Techniques (Product Development) for a detailed description of the treatment processes:

- **Option 1** – Pelletiser only
- **Option 2a** – Pelletiser and extruder
- **Option 2b** – Pelletiser and injection moulder

Options 2a and 2b are a second stage process, whereby the granules from Stage 1 output are transformed into commodities through an extruder (Option 2a) and an injection moulder (Option 2b). Remaining granules that are not used up in the Stage 2 process are then sold onto international markets and the commodities generated from the Stage 2 process are sold into the domestic market.

Other assumptions that apply to three options are:

- The viability of all three options is assessed over a period of 15 years. Accurately predicting the costs and benefits becomes challenging the longer the time horizon.
- 10 workers are considered across the three options, as this number strikes a good balance between part-time workers and full-time workers and enables the enterprise to have some flexibility around labour requirements while remaining as productive as possible.

The BCRs for the three proposed options are then calculated in terms of assessing the marginal (or additional) waste processing that can be conducted by a small-to-micro enterprise. Presenting the results of the analysis in this fashion shows decision makers of whether the additional costs of the new options are warranted by the additional benefits that are brought about in comparison to the base case.

Table 30 presents a summary of the costs and benefits that are associated with each Option.

**Table 30. Similarities and differences across the different options**

Parameter	Option 1	Option 2a	Option 2b
Capital expenses			
Factory/Building upgrading and refurbishment	✓	✓	✓
Pelletiser machinery		✓	
Extruder machinery			✓
Injection moulder machinery			
Operating expenses			
Rent	✓	✓	✓
Energy consumption	✓	✓	✓
Machine annual maintenance	✓	✓	✓
Wages	✓	✓	✓
Economic gains			
Revenues from plastic pellets	✓	✓	✓
Revenues from extruder products		✓	
Revenues from injection moulder products			✓

## Inputs and Assumptions

Table 31 below summarises the key inputs and assumptions involved in the economic analysis. The data has been gathered from a variety of different sources ranging from published academic papers, SPREP publications, grey literature, and a web search of retail data. This introduces variability into the input data and this uncertainty is captured through a sensitivity analysis. It's important to note that this data might not perfectly reflect the situation in every SIDS because each country has unique characteristics, so some information is taken from Fiji as a proxy estimate.

**Table 31. CBA inputs and assumptions**

Parameter	Units	L	M	H	Source
Discount rate	%	4%	7%	10%	Social discount rate from Infrastructure Australia
FJD USD exchange rate	FJD/USD	0.42	0.45	0.5	Google Finance 5-year historical average rate



Parameter	Units	L	M	H	Source
Energy cost	FJD per kWh	0.17	0.34	0.51	Energy Fiji Limited <a href="https://efl.com.fj/your-home/electricity-tariffs-and-rates/">https://efl.com.fj/your-home/electricity-tariffs-and-rates/</a>
Factory/facility size	sqm	100	125	150	MPS and NCE assumption. This is expected to also cover essential equipment purchases for occupational health and safety and have safe design measures for working in the facility.
Working hours per day	Hours	3	5	7	NCE assumption
Working days per year	Days per annum		250		NCE assumption
Hourly wage	USD per hour	2.7	3.6	4.5	NCE assumption based on an FJD 4 minimum wage with +-25% adjustment for the range
Land rent	FJD per sqm	10.5	21	31.5	NCE assumption based on data collected in previous projects in SIDS
Building and refurbishment cost	FJD per sqm	600	1,200	1,800	NCE assumption based on data collected in previous projects in SIDS
Maintenance cost (applies to all machinery)	% of machine cost	2.5%	3.75%	5%	NCE assumption
Pelletiser cost	USD per unit	4,000	6,000	8,000	Aggregated web search of online retailers
Pelletiser recovery potential	%	70%	80%	90%	Aggregated web search of online retailers
Pelletiser energy requirement	kwh	4	7.5	11	Aggregated web search of online retailers
Economic value of plastic pellets	\$ per kg	0.5	0.55	0.6	MPS and NCE assumption
Extruder cost	USD per unit	1,000	1,250	1,500	Aggregated web search of online retailers
Extruder recovery potential	%	70%	80%	90%	Aggregated web search of online retailers
Extruder weighted product value	USD per kg	1.08	2.17	3.25	Weighted estimate of potential products that can be generated from injection moulding based on a web search of online retailers
Extruder energy requirement	kwh	0.15	0.3	0.45	Aggregated web search of online retailers
Injection moulder cost	USD per unit	9,000	12,000	15,000	Aggregated web search of online retailers
Injection moulder recovery potential	%	70%	80%	90%	Aggregated web search of online retailers
Injection moulder weighted product value	USD per kg	0.99	1.98	2.97	Weighted estimate of potential products that can be generated from injection moulding based on a web search of online retailers

Parameter	Units	L	M	H	Source
Injection moulder energy requirement	kwh	0.35	0.7	1.05	Aggregated web search of online retailers

## Results

The results from the economic modelling are displayed in Figure 14. The ranges in the estimates are represented by the error bars for each option. Based on the BCR decision rule, all three options are considered to be economically viable over the assessment period of 15 years.

Option 2a has the highest BCR and this is followed by Option 1 and Option 2b. That is, for every USD 1 that is invested, there are returns of approximately USD 1.85, ranging from USD 1.26 to USD 2.64.

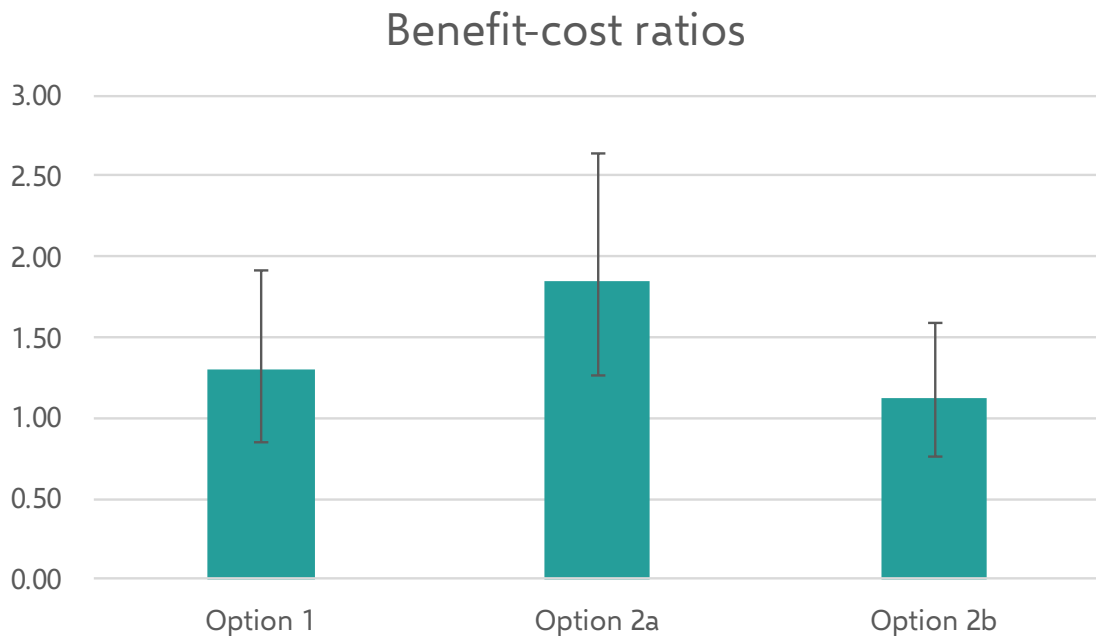

**Figure 14. BCRs for all three options**

The estimated values of the NPVs and BCRs are presented in Table 32. Other takeaways are:

- Not only does Option 2a report the highest BCR, but even at the P10 (low) estimate, there is still the possibility of generating positive net return. In contrast to Option 1 and Option 2b, the low estimates suggest that they both do not break even.
- Additionally, the P90 BCR estimate for Option 2a is highest among the three options, and this is followed by Option 1 and Option 2b. This means that Option 2a is favoured among the three options under an optimistic scenario.

**Table 32. Estimates of the NPVs and BCRs**

Options	NPV (\$ K) (P10 to P90)	BCR (P10 to P90)
Option 1	\$55.41 (-\$32.07 to \$155.82)	1.3 (0.85 to 1.92)

Options	NPV (\$ K) (P10 to P90)	BCR (P10 to P90)
Option 2a	\$173.27 (\$57.85 to \$308.98)	1.85 (1.26 to 2.64)
Option 2b	\$29.69 (-\$61.88 to \$134.38)	1.12 (0.76 to 1.59)

Note: The values in parenthesis represent the P10 (low) and P90 (high) values.

Figure 15 illustrates the cumulative cash flow, specifically focusing on the first 5 years of the assessment period. This is to highlight the amount of time required for each option to break even and generate profit. From this figure, Option 2a has a positive cash flow almost immediately in year 0, and this is followed by Option 1 breaking even and generating positive net cash flow in year 1. Option 2b is only able to break even and generate positive net cash flow in year 3 onwards.

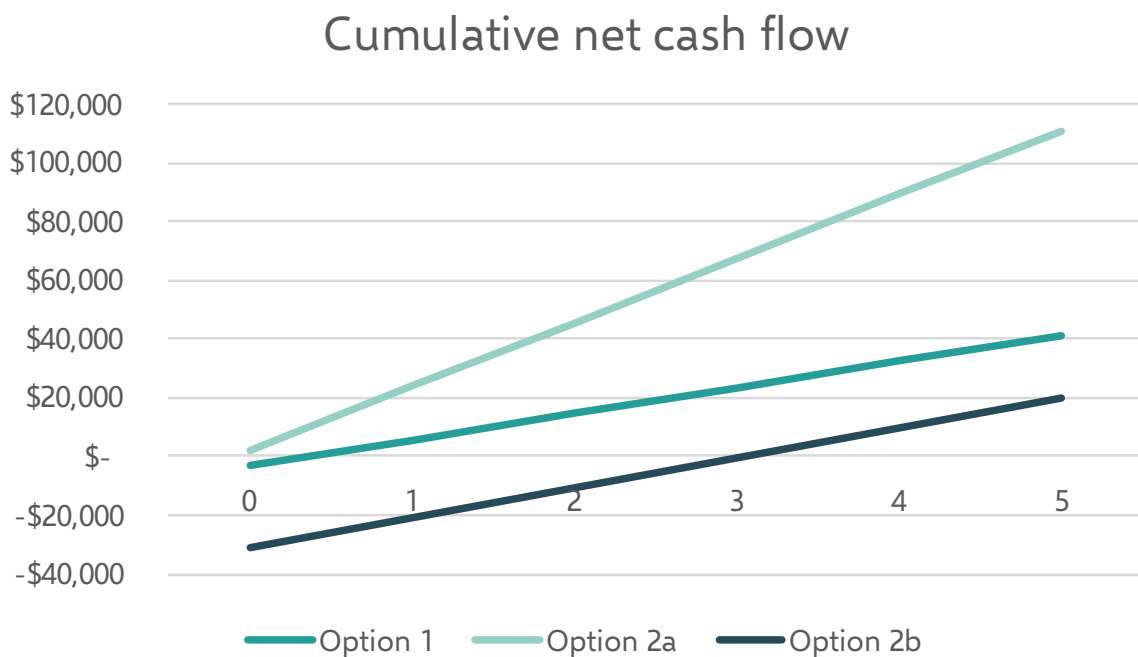

**Figure 15. Cumulative cash flow for the three options**

### Sensitivity Analysis

After considering these headline numbers, Figure 16 is presented to show which input parameters contribute the most to the variation to the BCR for Option 2a. The sensitivity data for Option 2a is presented as an indicative example for the rest of the other options. A positive value (bar on the right of the chart) means that that input parameter positively affects the BCR, and negative value (bar on the left of the chart) means that that value negative affects the BCR.

For example, an increase in the pelletiser product value is associated with an increase in the estimated value of the BCR, and an increase in land rental costs leads to a decrease in the value of the BCR. The extent of the bar presents the size of their influence on the variability. The extruder product value contributes to 13% of the variation in the BCR whereas land rental costs contribute to 25% (in absolute terms) of the variation of the BCR.

The 5 input parameters that contribute most to the variation in the BCR are land size, potential product value from the extruder, the pelletiser plastics requirement, land rent costs, and the enterprises operational hours. From this we can surmise that:

- The key input parameters that drive revenue growth are the available stockpile of pelletisers and the end product value for extruders. They both represent almost 40% of the total variation in the BCR. The number of available pelletisers can create a bottleneck in the production process.
- The cost of rental and the size of the facility's operating area represents 30% of the total variation in the BCR.
- The assumed working hours represent 27% of the variation in the BCR. This directly affects the productivity of the enterprise and determines how many pellets and Stage 2 products can be remanufactured. The machinery that we have considered here are reliant on manual labour to turn levers and sort plastics.

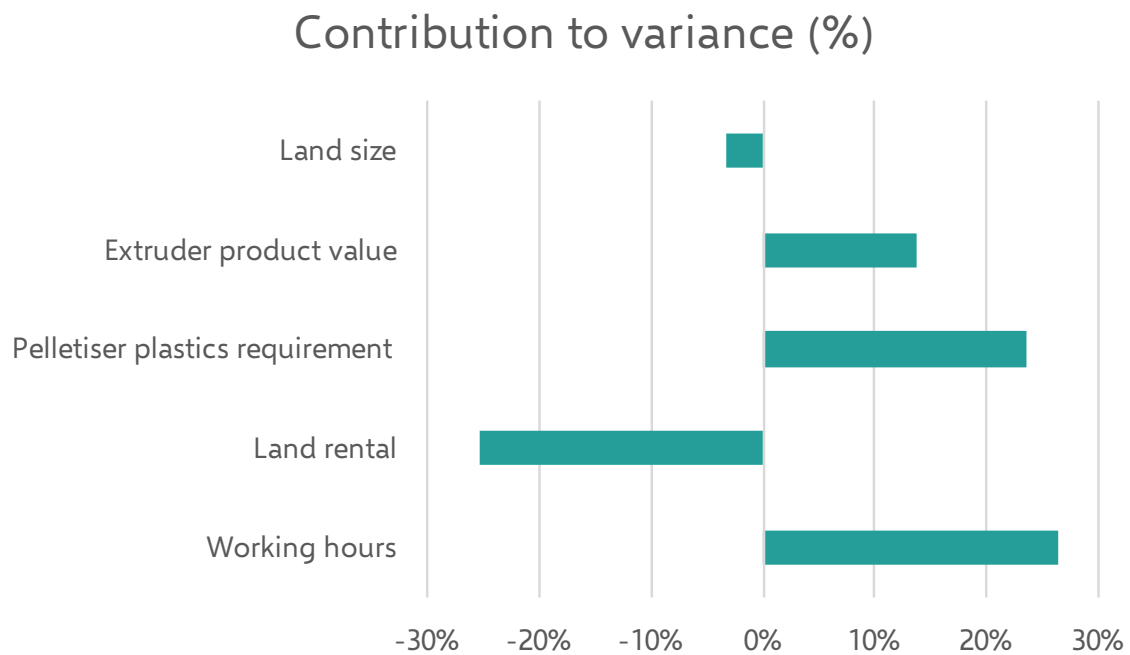

**Figure 16. Contribution to variance (Option 2a)**

## 6 Conclusion

This consultancy has identified mechanical recycling of the predominant plastic resin types, namely PET, HDPE, LDPE and PP to be the most suitable technologies, technically, economically and based on available shipping and capability levels for processing plastic waste into marketable commodities within Pacific Island countries. These technologies were found to be scalable, cost-effective, and potentially environmentally sustainable if supported by government and/or private sector finance frameworks (CDL/ARF/LEVY/EPR).

Given the considerable differences in the Pacific in population, technical expertise, market access and finance it is considered that not all the mechanical recycling end points were suitable for all countries. Table 33 has therefore been produced to provide recommendations on the recycling end points considered to be suitable for each of the 13 Pacific Island countries.

**Table 33 PIC recommended technology choices**

Type of User	Tech Options	Micro Enterprises	Small Enterprises
Basic, low volume	Granulation	Nauru Niue Palau Tuvalu	Cook Islands FSM Kiribati PNG RMI Tonga Samoa Solomon Islands Vanuatu
Moderate expertise, low volume or basic expertise and high volume	Pellets	Palau Samoa Tonga	Fiji Solomon Islands Vanuatu PNG
Higher Expertise, higher volume	Extrusion	Palau Samoa Tonga	Fiji PNG Vanuatu Solomon Islands
	Injection		Fiji PNG Vanuatu Solomon Islands
Specialist	Blow		Fiji PNG
	Vacuum		Fiji PNG

The review found that there is sufficient plastic waste in the supply chain, technical capability and more moderate sources of infrastructure funding to support mechanical recycling operations, as well as being proven technologies with well-defined international market end points (rPlastic flake, granules and pellets) that are accessible to Pacific recyclers. These end points are highly scalable with a small-scale recycler being able to produce a few shipping containers a year or thousands (Section 2.4 Mechanical Processing).

The review did not find there was sufficient feedstocks to sustain commercial waste energy or chemical recycling, both which require vast quantities of plastics (tens of thousands of tonnes), with only PNG approaching such quantities (see Table 3) and much higher levels of technical capability and funding. The energy and fuel end points are also not well known in the Pacific, they cannot be readily exported (unknown quality) and if consumed nationally would need to meet quality or energy system input standards (Section 2.4 Energy and Chemical Recycling).

While existing recyclers can be trained to operate mechanical recycling operations (similar to existing recycling equipment for metals, cardboard) the skill sets for commercial energy and chemical recycling are at a far higher technical level and do not currently exist in the Pacific. Even in Australia and New Zealand energy and chemical recycling from plastic is controversial, largely research based with an unproven business case. As noted in the recommendation section chemical recycling is used on less than 1% of plastic waste globally. This is not a suitable commercial technology for a small-scale recycler.

The market demand for recycled commodities, especially granulated and pelletised is well established but still unserved by plastic from Pacific recyclers. This is because none of the larger Pacific Island countries have effective collection systems such as kerbside or container deposit systems to concentrate plastics. Only the Micronesian countries of Kiribati, Palau, RMI and FSM have them. Being smaller they have only modest quantities and have been unsupported in moving from baled PET to granulated. In the Pacific, even when Moana Taka is applicable, the lack of an external subsidy support system means that many plastic recycling initiatives are not financially viable.

In Australia the PET market is relatively new and to date has offered poor prices as it has been well supported by the Australian Kerbside and CDL systems and quarantine concerns which have been barriers. Attempts by Pacific recyclers to export to Australia have not been encouraging, though with rPET products in high demand due to legislative requirements on recycled content this may improve. There are at least four rPlastic recycling plants now in operation in Australia seeking plastic content, but successful import pilots are needed from the Pacific to prove to both Pacific and Australian recyclers it can work.

The international market for recycled plastics is well established with literally thousands of buyers of every grade of plastic. Navigating this is extremely complex as is securing viable prices. There is also a need to prove to the market buyers that the seller has the required the quality, quantity and reliability to be offered premium prices. This is an identical process to that which already occurs for non-ferrous metals and can be emulated; however, it requires expertise to be established. For plastics, this form of assistance to reach the market has yet to be provided.

There is a need for donors, government and the private sector to have strategic engagement to develop and operationalise such plastic recycling and to effectively engage and integrate community and special interest stakeholders to best effect.

Existing recyclers can act as a focal point to grow new recycling enterprise and are keen to engage as shown through their endeavours with the range of case studies that are presented in the report. But as cautioned future case studies, pilot projects and demonstrations need to be based on good business fundamentals matched to development of sustainable frameworks by the government.

It would require well planned and supported projects for the Pacific to finally bridge this gap and supply Oceania as well as Asian markets with quality recycled plastic products in the same way it has been long providing ferrous and non-ferrous metals, mineral, fisheries and agricultural products.

## 7 Recommendations

### Support Proof of Concept Pilots and Demonstrations to Collect Data

As noted above there are many activities which have not organically occurred as (1) plastics are not concentrated by kerbside of CDL systems in the larger Pacific Island countries, (2) the international market requirements for recyclable plastic products are not understood in the Pacific, and (3) there is no knowledge on how to access value added plastic markets. Therefore, there is a need to conduct a range of pilots and demonstration projects to gather such data, to support plastic collection, processing, and export, and to access suitable experts and markets for recycled plastics.

The first low hanging fruit is for value added PET products to be produced for international export or use in the Pacific. This information could be used to potentially standardise PET products across the Pacific for the most viable markets. Smaller batches of HDPE, PP and other plastics could also be trialled.

It is therefore recommended that project support is given to pilots and demonstration projects that can support plastic recycling moving forward in the Pacific from current levels.

### Conduct Market Research on Potential Products

In review of the plastic recycling pilots in the Pacific, it is apparent that market research has not been conducted. From the pyrolysis products, Palau (Koror State Government Energy Recovery Facility) and Solomon Islands (Nufuels), to the plastic briquettes in Fiji (Precious Plastic), there was no evidence that market research had been conducted and significant questions remain unanswered. Would the fuel or infrastructure markets in those countries accept such a novel product? Could they meet the national standards and requirements? Could they meet critical price points? Would the market accept them?

It is recommended that plastic processing choices are informed by targeted market research to avoid producing something no one wants, can afford, or can legally/safely use.

### Ensure the Business Case

The business case needs to be ensured before investing time, funding and other resources. This should be thoroughly examined for each plastic recycling technology chosen to ensure feedstock can be accessed affordably. CAPEX and OPEX can be supported by sales, logistics, human resources, taxes and other factors. This can be conducted as a desktop, followed by a targeted pilot and a demonstration plant to progressively test the business case and protect investments.

It is recommended that the business cases for plastic recycling proposals are established before investments are made.

Do not prioritise unproven methods (chemical) at scale over proven mechanical recycling methods.

There is need for increased innovation and new recycling technologies however, we caution against adopting unproven technologies at scale. Demonstrating the effectiveness of processing systems, their environmental impact, market viability, and material purchase rates is crucial. For example, although chemical recycling may theoretically be best suited for hard to recycle plastic in larger developed countries, currently less than 1% of all plastic is recycled in this way (Plastics Europe, 2022),



most are unproven, in a research phase, and without a proven business case. Over 90% of all plastic recycling involves proven mechanical recycling methods with established markets, global price indices and with well understood processing requirements and equipment needs.

It is recommended that proven recycling technologies are prioritised, which for the Pacific means scalable mechanical processing rather than chemical.

### **Strategic Engagement Between Donors, Government and the Private Sector will Harmonise Recycling Priorities and Actions.**

There is a need for donors, government and the private sector to have strategic engagement to develop and operationalise such plastic recycling and to effectively engage and integrate community and special interest stakeholders to best effect.

It is recommended that platforms, like the recycling associations set up by JICA, are established or further bolstered to engage donors, government and the private sector in a common space.

### **EPR or Other Clear Financial Support Systems (e.g., CDL) will Improve the Sustainability of Plastic Recycling.**

Extended Producer Responsibility (EPR) was highlighted as a current solution for addressing recycling challenges. EPR shifts financial responsibility from municipalities and taxpayers to producers, ensuring a secure funding mechanism covering various recycling stages. EPR enhances data collection and transparency in recycling systems, facilitating the evaluation of new technologies in the future. It fundamentally transforms the funding structure for recycling nationwide. We suggest that for plastic recycling that a proven operational funding mechanism such as EPR or Container Deposit Legislation will be an important factor in the successful and sustainable collection of plastics (especially for difficult to recycle materials). Pilot work on plastic recycling without support via EPR (Mission Pacific Fiji) or CDL (Palau, RMI, Kiribati) has shown the current gap in product value compared to collection, processing and export costs makes it unviable even for PET plastic.

It is recommended that EPR, CDL, ARF systems are established in the medium to long term to support plastic recycling and that project support funds are used in the short term to test recycling systems.

### **Provide Strategic Funding, Technical Know-How, Market Knowledge, and Access to Grant Schemes to Business and Industry.**

Recyclers have a great interest in becoming more circular but need assistance with government (CDL/ARF/Levy) or industry frameworks (EPR) to build sustainable recycling systems on par with profitable non-ferrous wastes.

It is recommended that the system should include specific designations for private business and industry with strategic funding, technical know-how, and market knowledge to best transition to a lower SUP environment with greater circularity of materials needed for their business.

It is also recommended that business and industry are provided with access to, and explicit guidance on how to access, grant and/or low interest loans, infrastructure and land, technical and market expertise to transition to plastic recycling and value adding.

### **Identify, Develop and/or Attract Capability.**

There is little capability for processing plastics into viable marketable products in the Pacific. Only baled plastic has been intermittently exported and some granulation, moulding and micro-scale pyrolysis has occurred. To develop more robust plastic recycling that can be sustained and produce marketable products, much greater levels of technical, operational and business capability is needed. This could be provided to existing recyclers through twinning support from established business (Asia for example), developed independently from existing business (i.e., a new purpose built operation) through a long term (multiyear) supported project, or be attracted through offering incentives for established business able to conduct to set up in the Pacific.

It is recommended that structured project and policy approaches are used to identify, develop and attract the capability needed to successfully run plastics recycling systems. This could be done through targeted hire, twinning or invitation.

### **Establish Local Training Centres as the Repository of Recycling Skills Knowledge and Transfer.**

For the recycling systems to transition from donor dependant and one time training seminars where knowledge quickly diminishes and is lost following project closure, a constant and reliable source of training and knowledge retention is needed. In the Pacific it is not uncommon for a successful micro or small enterprise to cease operation when the individual operating it retires or steps away. This secures the sustainability, transferability, and standardises the long term skillsets required for recycling operations. This is also particularly important for more highly skilled plastic recycling operations (i.e., Stage 2) where specific plastic focused education can be reviewed, retrained, and retested to maintain skillsets of the workforce whilst also qualifying staff and legitimising the otherwise stigmatised practice of working in waste.

It is recommended that local training centres (such as technical schools, vocation educations centres, or the like) are assisted with establishing courses specific to recycling operations (technical and business) and reverse logistics.

### **Develop Improved Access Routes to Moana Taka Program for Recyclers Across the PICs.**

Moana Taka program being a ground-breaking but underutilised initiate. Swire Shipping has expressed interest on expanding its role from an already important component for plastic wastes in the Pacific, for 8 or 9 of the 13 PICs. It has enabled PET bales to be exported from Fiji even in the absence of a CDL system with some PET being shipped via MTP from RMI, Vanuatu and Samoa.

It is recommended that support is provided to recyclers within the qualifying PICs to help access and understand the initiate.

### **Seek to Include Diverse Groups of People in All Recycling Opportunities While Endeavouring to Reducing Unequitable Distribution of Labour.**

Embracing this diversity and incorporating traditional knowledge can lead to more holistic and culturally appropriate solutions. From a social inclusion standpoint, engaging youth, the elderly, and marginalised groups in the development and implementation of plastic waste management strategies is essential. However, there is a general concern that the potential job creation in a recycling network may not be equitably distributed, with certain groups (e.g., youth, ethnic minorities) facing barriers to employment due to discrimination.

It is recommended that there is targeted outreach, ongoing capacity-building and training, and the creation of recycling platforms and networks for diverse voices to be heard.

# References

- ADB, (2020). Waste To Energy In The Age Of The Circular Economy Best Practice Handbook.
- Al-Salem, S. M., Lettieri, P., & Baeyens, J. (2009). Recycling and recovery routes of plastic solid waste (PSW): A Review. *Waste Management*, 29(10), 2625–2643.  
<https://doi.org/10.1016/j.wasman.2009.06.004>
- Chappell, B., Pramanik, A., Basak, A. K., Sarker, P. K., Prakash, C., Debnath, S., & Shankar, S. (2022). Processing Household Plastics for recycling – A Review. *Cleaner Materials*, 6, 100158.  
<https://doi.org/10.1016/j.clema.2022.100158>
- Deloitte, (2021). Pathways towards circular economies.  
<<https://www.deloitte.com/content/dam/assets-zone2/be/en/docs/industries/energy-resources-industrials/2023/be-deloitte-circular-plastics.pdf>>
- Dodbiba, G. and Fujita, T. (2004) 'Progress in separating plastic materials for recycling', *Physical Separation in Science and Engineering*, 13(3–4), pp. 165–182. doi:10.1080/14786470412331326350.
- Dodbiba, G., & Fujita, T. (2004). Progress in separating plastic materials for recycling. *Physical Separation in Science and Engineering*, 13(3–4), 165–182.  
<https://doi.org/10.1080/14786470412331326350>
- Gemini Group (2018) Blow molding design guide, GeminiGroup. Available at:  
<https://geminigroup.net/wp-content/uploads/2018/06/Blow-Molding-Design-Guide-by-Regency-Plastics.pdf>
- Gent, M.R. et al. (2009) 'Cylinder Cyclone (LARCOCODEMS) density media separation of plastic wastes', *Waste Management*, 29(6), pp. 1819–1827. doi:10.1016/j.wasman.2008.12.026.
- Geyer, R., Jambeck, J. R., & Law, K. L. (2017). Production, use, and fate of all plastics ever made. *Science advances*, 3(7), e1700782.
- Grigore, M.E. (2017). Methods of Recycling, Properties and Applications of Recycled Thermoplastic Polymers. *Recycling*, 2, 24.
- Hopewell, J., Dvorak, R., & Kosior, E. (2009). Plastics recycling: Challenges and opportunities. *Philosophical Transactions of the Royal Society B: Biological Sciences*, 364(1526), 2115–2126.  
<https://doi.org/10.1098/rstb.2008.0311>
- J-PRISM II, (2023). SRWMA/J-PRISM II Pilot Project Completion Report
- JICA, (2016). Verification Survey with the Private Sector for Disseminating Japanese Technologies for Promoting Collection, Segregation and Reduction of Solid Waste by Recycling Plastic Waste to Oil.
- La-Plastic.com (2023) What are the different types of vacuum forming?, la. Available at:  
<https://www.la-plastic.com/post/what-are-the-different-types-of-vacuum-forming>.
- Lau, M. (2023) A comprehensive guide to plastic shredders for the recycling industry: Types, components, maintenance, and sourcing, Nicety Plastic Machinery Co., Ltd. Available at:

<https://nicetymachine.com/a-comprehensive-guide-to-plastic-shredders-for-the-recycling-industry-types-components-maintenance-and-sourcing/>.

Locock, KES (2017) *The Recycled Plastics Market: Global Analysis and Trends*. CSIRO, Australia.

Mission Pacific, (2024). FAQ Page <<https://www.missionpacificfiji.com/faq/>>

Morales Ibarra, R. et al. (2014) 'Carbon fiber recovery using water and benzyl alcohol in subcritical and supercritical conditions for chemical recycling of thermoset composite materials', *Journal of Material Cycles and Waste Management*, 17(2), pp. 369–379. doi:10.1007/s10163-014-0252-z.

Naderi Kalali, Ehsan et al, "A Critical Review of the Current Progress of Plastic Waste Recycling Technology in Structural Materials" (2023) 40 *Current opinion in green and sustainable chemistry*.

Nayanathara Thathsarani Pilapitiya, P. G. C., & Ratnayake, A. S. (2024). *The World of Plastic Waste: A Review*. *Cleaner Materials*, 11, 100220.

Nicholls, Bryce T and Brett P Fors, "Closing the Loop on Thermoset Plastic Recycling" (2024) 384(6692) *Science (American Association for the Advancement of Science)* 156

Niessner, Norbert (ed), *Recycling of Plastics* (Hanser, 1st ed., 2022)

NuFuels. (2024). Solomon Airlines and NuFuels announce innovative program to turn waste to recovered energy. <https://www.nufuels.biz/news/solomon-airlines-and-nufuels-announce-innovative-program-to-turn-waste-to-recovered-energy-in>

OECD. (2018). *Improving markets for recycled plastics: Trends, prospects and Policy Responses*.

Okiy, Stanley & Emagbetere, Eyere & Oreko, Benjamin & Okwu, Modestus. (2018). *Design and Fabrication of Polythene Pelletizing Machine for Urban Communities in Nigeria*.

Plastic shredder (no date) *Plastic Shredder Systems*. Available at: <https://plasticshredder.com/>

Ragaert, K., Delva, L., & Van Geem, K. (2017). Mechanical and chemical recycling of solid plastic waste. *Waste management*, 69, 24-58.

Sea Studios Foundation. (n.d.). *Smart Plastics Guide*. <https://www-tc.pbs.org/strangedays/pdf/StrangeDaysSmartPlasticsGuide.pdf>

Shen, L., & Worrell, E. (2014). Plastic recycling. *Handbook of Recycling*, 179–190. <https://doi.org/10.1016/b978-0-12-396459-5.00013-1>

Solomon Airlines. (2022, April). Solomon Airlines & NuFuels announce innovative program to turn waste into recovered energy in Solomon Islands. <https://www.flysolomons.com/about-us/news/general/solomon-airlines-nufuels-announce-innovative-program-to-turn-waste-into-recovered-energy-in-solomon-islands-april-2022>

SPREP. (2020a). *Plastic waste: Waste technology management options*.

SPREP. (2020b). *Assessment of small-scale technology suitable for Waste Management in the Pacific and Timor-Leste*.

SPREP. (2021). *Waste Energy Research report*.

SPREP. (2024). Practitioner's guideline on depollution on end-of-life-vehicles.

Steven (2021) Various plastic molding process, Topworks plastic molding company. Available at: <https://www.plasticmoulds.net/various-plastic-molding-process.html>

Thermosets and thermoplastics: Definition and differences. INFINITIA Industrial Consulting. (2022, August 30). <https://www.infinitiaresearch.com/en/news/thermosets-and-thermoplastics-definition-and-differences/>

Vollmer, I., Jenks, M. J., Roelands, M. C., White, R. J., van Harmelen, T., de Wild, P., van der Laan, G. P., Meirer, F., Keurentjes, J. T., & Weckhuysen, B. M. (2020). Beyond Mechanical Recycling: Giving new life to plastic waste. *Angewandte Chemie International Edition*, 59(36), 15402–15423. <https://doi.org/10.1002/anie.201915651>

Wong, J.H. et al. (2022) 'Shredder machine for plastic recycling: A review paper', *IOP Conference Series: Materials Science and Engineering*, 1217(1), p. 012007. doi:10.1088/1757-899x/1217/1/012007.

Yao, S., Tominaga, A., Fujikawa, Y., Sekiguchi, H., & Takatori, E. (2013). Inner structure and mechanical properties of recycled polypropylene. *Nihon Reoroji Gakkaishi*, 41(3), 173-178.

# Appendices

Stakeholder engagement plan

A

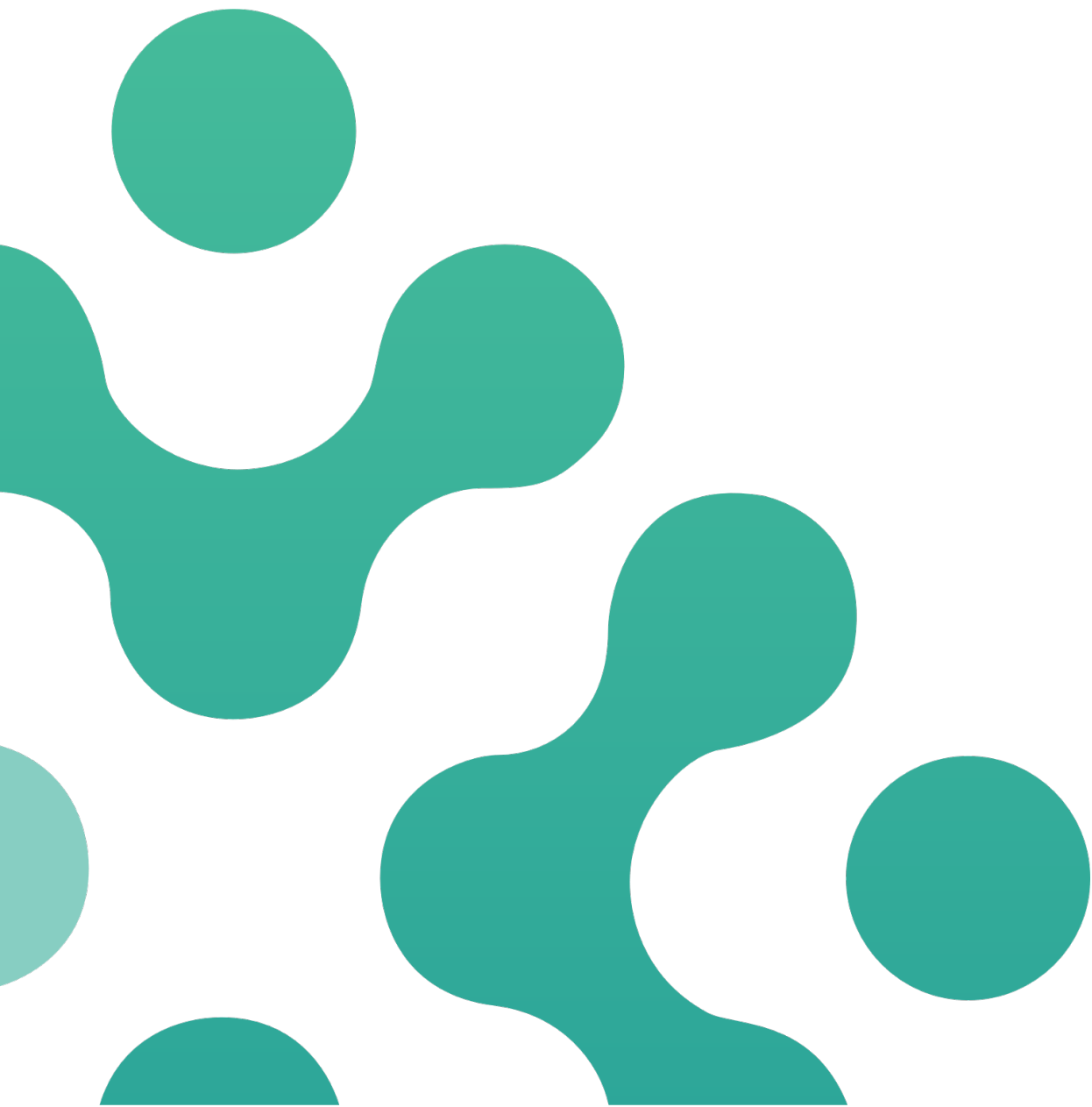

# Engagement plan

## Communication and engagement objectives

The communication and engagement objectives of this project are to:

1. Ensure a high degree of independence in how the project is undertaken.
2. Use a collaborative process ensuring key stakeholders and experts in the region (Community, special interest, business, and government) have an opportunity to provide input to the project and are kept aware of the outputs.
3. Ensure the science and expert knowledge used in the review is open and transparent.

## What will success look like? (communication and engagement outcomes)

We consider stakeholder engagement to be a key aspect of this project to ground truth, and to identify knowledge gaps and key constraints. The different stakeholders may hold different opinions about the key constraints or which knowledge gaps should be prioritised, however, the project's communication and engagement will be considered a success if:

- The stakeholders involved in the meetings have been respectful and professional in expressing their views and have been constructive in jointly identifying any factors overlooked and potential incompatibilities or conflicts.
- There is broad acceptance that the best possible outcome has been achieved based on the constraints of the project including available data and state of the science, competing stakeholder interests and views.
- There is acceptance that the key considerations identified for future development, the prioritised knowledge gaps, and next steps determined from this project provides a way forward for subsequent projects.



## Online engagement strategy

The following list outlines some of the possible techniques that can be used to maximise the value of online or remote engagement.

### Technologies, engagement techniques, and knowledge sharing opportunities for use prior to and post in-person components.



Pre-reading materials summarising:

- What constitutes plastic pollution and its overall negative impacts.
- The current situation for public
- The current situation for government and businesses
- Potential actions and solutions from around the globe, an introduction.



Personal reflection

- What knowledge gaps exist for:
  - o Business
  - o Industry
  - o Community
  - o Government
- What technical gaps exist for:
  - o Business
  - o Industry
  - o Community
  - o Government
- What barriers to your engagement exist?



On-line survey e.g. Survey Monkey, Menti Meter, Poll Everywhere

### Technologies, engagement techniques, and knowledge sharing opportunities for use during in-person components.



Zoom™ webinar incorporating use of interactive snap polls, survey, and Q&A tool (including ability to promote and 'like' other's questions). Zoom webinar allows for multi-media videos to be developed and made accessible to stakeholders post-webinar.



Email: Invitation to participate in consultation processes via email. Notification and sharing of pre-reading materials with consultees. Follow up (if required).



Zoom™ meetings incorporating use of interactive snap polls, Chat, Break out rooms, Whiteboard. Zoom meetings allows for multi-media videos to be developed and made accessible to stakeholders post-webinar.



Use of third-party collaborative platforms e.g. MURAL™, Google JamBoard, Menti-Meter, Survey Monkey, Poll Everywhere etc.

Pre-populated templates.



Knowledge sharing e.g. case studies and scenarios provided by participants.



On-line editing Google Forms™ (or similar).

**Technologies, engagement techniques, and knowledge sharing opportunities for use post in-person components**



Multi-media video (post-webinar)

## Integrating GEDSI

Gender equality, disability and social inclusion (GEDSI) is aimed at the inclusion of disadvantaged and socially marginalised groups by promoting equal opportunities and benefits whilst also safeguarding against unintentional harm and further disadvantage<sup>21</sup>. It is important that GEDSI takes an intersectional approach that considers how different social factors, parts of peoples identities and their experiences combine to disadvantage them or afford them privilege<sup>22</sup>. In taking this approach it is possible to gain a strong understanding of individuals and groups access to assets, their beliefs and perceptions, their practices and participation, the ways that institutions, laws, and policies impact their lives, and how all these factors intersect to determine their power within their societies.

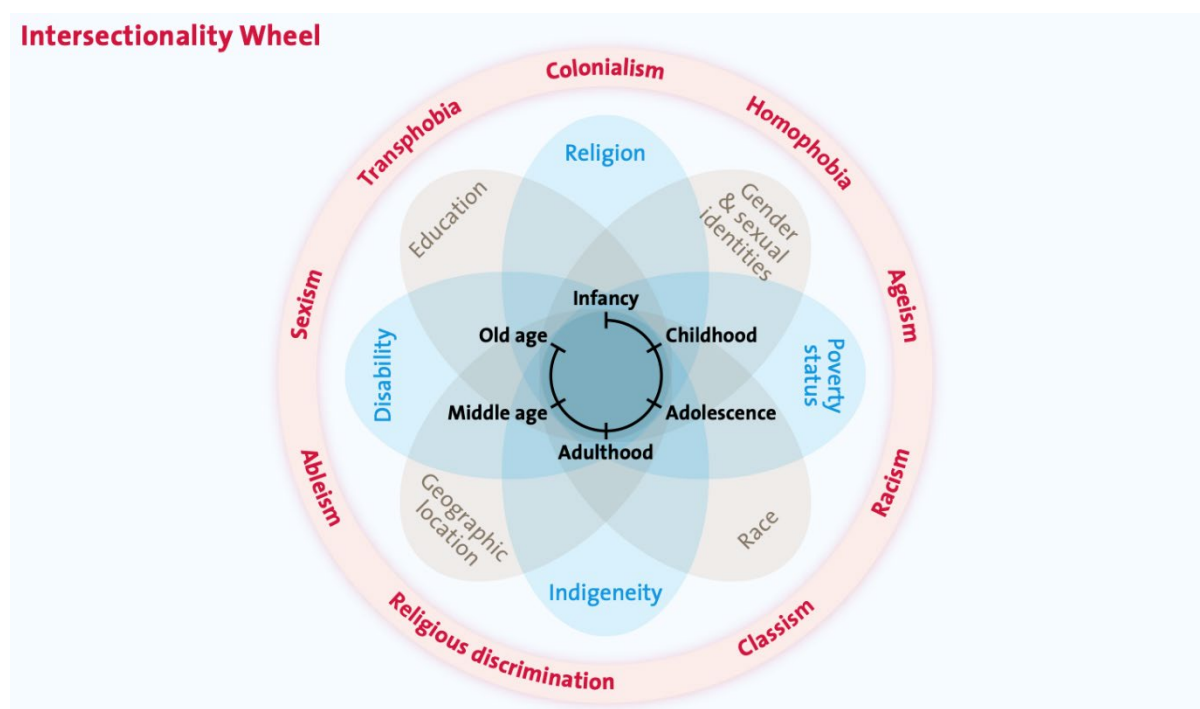

Source: UN Women Intersectionality Resource Guide and Tool Kit

In the Pacific context disadvantaged and marginalised groups include women, children, youth, people with disabilities (PWD), and LGBTQIA+ people, as well as other contextually marginalised minorities. Sociocultural norms, practices and power dynamics such as village chief systems, *Wantok* and *Kastom* (which are of high significance in Melanesia), and organised faith are integral to the lives and behaviours of people within the PICs<sup>23</sup>. Therefore, we recognise that it is important to be aware of how

<sup>21</sup> Department of Foreign Affairs and Trade (DFAT) Australia, 2023 <https://www.dfat.gov.au/sites/default/files/gender-equality-disability-social-inclusion-analysis-good-practice-note.pdf>

<sup>22</sup> UN Women, Intersectionality Resource Guide and Tool Kit, <https://www.unwomen.org/sites/default/files/2022-01/Intersectionality-resource-guide-and-toolkit-en.pdf>

<sup>23</sup> Asian Development Bank (ADB) 2023, <https://development.asia/explainer/participation-tools-pacific-part-1-engaging-pacific-civil-society-organizations>

these sociocultural factors will affect the consultative process and to take measures to ensure that everyone is able to participate openly and fully.

Within the project the inclusion of GEDSI and intersectionality focussed analysis in the design and consultation processes will ensure that the concerns, barriers, experiences and aspirations of all will be taken into consideration in designing and implementing businesses opportunities to improve plastic waste management and waste to commodity enterprises in the Pacific region.

### **GEDSI Stakeholder Consultation Goals**

- Equal participation of men and women
- Flexible consultative mediums (Zoom conferencing, online survey) to ensure broad participation
- Use of simple non-technical language
- Consultation with GEDSI focussed CSOs
- Ensuring women-only forums are facilitated to capture their voices
- Creating at least one opportunity for a women-run enterprise
- Investigation into existing plastic waste focussed enterprises and organisations (as well as those focussed on other waste materials which have the potential to expand their operations to include plastic) run by GEDSI focussed groups (e.g., PlasticWise Gizo)
- Investigation into the potential to expand and connect existing GEDSI focussed plastic waste operations to make them inter-Pacific so that existing knowledge of challenges/barriers and strengths/weaknesses may be drawn on

## Stakeholder Identification, Tools and Analysis

This project has a strong focus on stakeholder inclusivity. We define this as the effective involvement of all public and private stakeholders in the decision-making process, as well as relevant donor agencies and the effective participation of all stakeholders in the collection and recycling systems.

Stakeholders, such as business and industry (e.g., tourism industries, retailers, and waste businesses), special interest groups (e.g., civil society organisations (CSOs), non-government organisations (NGOs), women’s organisations), local communities (i.e., consumers), and government entities (state and local) are key groups in driving the process to prevent waste and to properly collect, process, and recycle the waste which cannot be avoided.

The team has made a preliminary list which will be further developed especially in relation to Local Community and Interest Groups in relation to GEDSI issues. We look forward to the POLP team advising on other stakeholders they would like the team to consult with.

**Table 34 Pacific Island Stakeholder List**

Country	Stakeholder Group	Stakeholder Name/Org.	Name of Representative
Cook Islands	Business and Industry	Rarotonga Waste Facility	Jaime Short
	Government	Manager Environmental Partnerships	Hayley Weeks
		National Environment Services	Vavia Tangatataia
Fiji	Interest Groups	Pacific Waste Foundation	Tanya Yanuyanurua
		Fiji Waste Association	Andrew Irvine
		University of the South Pacific	Andrew Irvine
	Business and Industry	Waste Recyclers Fiji Ltd	Joseph Inoke-Deo
		Pleass Global	Warwick Pleass
		Asia Pacific Engineering	Elizabeth Jacinta
		Coca-Cola Amatil ‘Mission Pacific Fiji’	Mathew Lomaloma
Fiji Recycling Association	Amitesh Deo		

Country	Stakeholder Group	Stakeholder Name/Org.	Name of Representative
		Punjas Group	Navneet Prasad
		South Pacific Waste Recyclers	Sanjay Kirpal
		Waste Recyclers Fiji Ltd	Joseph Keiler
		Waste Clear	Subhas Chand
		Fiji Water	Melissa England
		Paradise Beverages	Sudha Deo
	Government	Department of Environment	Sandeep Singh
		Ministry of tourism	Jotishna Reddy
FSM	Business and Industry	Island Paradise Metal Company	Jesse Faimaw
		Micronesia Eco, Corp	Richard M Stephens
	Government	DECEM	Andrew Yatilman
Kiribati	Business and Industry	Koaki Mange	Derek Stevens
		Macaulay Metals Ltd	Jeff Harris
	Government	Waste Management & Pollution Prevention Environment and Conservation Division	Taulehia Pulefou
Marshall Islands	Business and Industry	RMI Recycling Company	Yen T Sheng
		Majuro Atoll Waste Company (MAWC)	Halston deBrum
	Government	RMI EPA	Moriana Philips
Nauru	Business and Industry	Capelle	Kenneth Oppenheimer
	Government	DCIE/DEMA	Ms Berilyn Jeremiah
		Director of Environment	Bryan Star
Niue	Interest Groups	Catholic Church	Father Anaua Finau
	Government	NDE	Haden Talagi
Palau		Belau Garbage and Scrap Company	Sam Masang

Country	Stakeholder Group	Stakeholder Name/Org.	Name of Representative
	Business and Industry	Chao Tai CT Shop	Jilly & Sheila
		Palau Waste Company	Michael Yiao
	Government	EQPB	Roxanne Blesam
		Koror State Recycling Centre	Katsio Fuji/Selby Etibek
PNG	Interest Groups	University of Papua New Guinea - Vice Chancellor	Prof. Frank Griffin
	Business and Industry	Total Waste Management	Kori Chan
		PNG Recycling	George Doonan
		Goldchin (PNG) Ltd	Stephanie Chan
		Hythes Limited	Duma Wilson
		NCDC - Waste Manager	John Navara
		Branis Recycling	Peter Karu
	Government	CEPA	Yvonne Tio
CEPA - Manager Infrastructure, Utilities and Convention Division		Veari Kula	
Samoa	Interest Groups	Recyclers Association	Marina Keil
	Business and Industry	Samoa Recycling	Marina Keil
	Government	MNRE	Frances Debra Brown-Reupena
			Setoa Siaoisi
			Setoa Apo
		ACEO-Waste Division MNRE	Katenia Rasch
Principal Waste Management Officer, MNRE	Aliimuamua Setoa Apo		
Solomon Islands	Local Community	Women in Bisnis	Teiba Mamu
		Friends of the City	Judah Suimae
	Interest Groups	PlasticWise Gizo	Rendy Solomon

Country	Stakeholder Group	Stakeholder Name/Org.	Name of Representative
		CAUSE	Nadia Mahmood
	Business and Industry	Oceania Recycling Solutions	Kenneth Williams
		SolPower Recycling	Mikey Maefiti
		373 Recycling	Anthony Ele
		Gizo Recycling	Rendy Solomon
		BJ5 Recycling	Sebastion Ilala
		Top Environment Recycler	Hammy Si
	Government	MECDM	Melchior Mataki
		MIN Tourism	Bartholomew Parapolo
		MECDM	Karl Kuper
			Debra Kereseke
		Honiara City Council	Andrew Nixon
		John Clemo	
	Tonga	Local Community	No Pelestiki
Interest Groups		SPTO	Christina Gale
Business and Industry		GIO Recycling	'Ofa Tu'ikolovatu
Government		Department of Environment	Ms Mafile'o Masi
Tuvalu	Local Community	TANGO	Mine Pilikosi
	Business and Industry	Waste Levy Committee	Timuani Selu
	Government	Department of Waste Management	Epu Falega
Vanuatu	Local Community	VESS	Christina Shaw
	Interest Groups	World Vision International	Bathany Boyer-Rechlin
		Live and Learn	Karlene Tevi



Country	Stakeholder Group	Stakeholder Name/Org.	Name of Representative
		USP	Krishna Kotra
	Business and Industry	RecycleCorp	Andrew Hibgame
		Vanuatu Breweries	Teiva Durand
	Government	DEPC	Touasi Jane Tiwok
		Acting Director, Department of Environment	Mr. Trinison Tari
		Officer In Charge, Environment Protection Division, Department of Environment	Mr. Dean Wotlolan
		Acting Principal Provincial Outreach Coordination and Communication	Mr. Rontexstar Mogerer

**Table 35 Regional CSOs**

Stakeholder Name/Org.	Name of Representative
Pacific Youth Council	Tahere Siisiialafia-Mau
Pacific Disability Forum	Mr. Setareki Macanawai
Women Enabled International	Maryangel Garcia-Ramos
Pacific Women's Professional and Business Network	Loau Donina Vaa's
Pacific Sexual & Gender Diversity Network (Pacific LGBTQI Network)	Nasik Swarmi
FemLINKPacific	Sulueti Waqa
PIANGO - Pacific Islands Association of Non-Governmental Organizations	PIANGO Secretariat
South Pacific Tourism Organisation	Christopher Cocker
Pacific Conference of Churches	Rev. James Bhagwan

**Table 2 Multilateral Organisation Stakeholder List for Development and Aid**

Stakeholder Group	Stakeholder Name/Org.	Position of Representative
ADB	Aimee Hampel-Milogrosa	Urban Development Specialist

ANZPAC	Angela Mayer	Program Manager
DFAT	Natasha Verma	Programme Manager
EU	Andre Vidal	Programme Manager
GIZ	Dirking, Vanessa	Deutsche Gesellschaft fuer Internationale Zusammenarbeit (GIZ) GmbH;
	Laurent, Janina Marie	Deutsche Gesellschaft fuer Internationale Zusammenarbeit (GIZ) GmbH;
IUCN	Paula Katiwara	Regional Co-ordinator Fiji
	Maria Muavesi	Head Environmental Legal Officer, Environmental Law Programme Pacific Centre for Environmental Governance (PCEG)
JICA/JPRISM	Junya Kikuhara	JICA Expert (3R and Return)
	Faafatai Sagapolutele	Assistant Chief Technical Advisor
MFAT	Caitlin Goggin	Policy Officer
Plastic Waste CRC	Ian Dagley	Chief Executive Officer
PRIF	Lorena Estigarribia	Project Officer
USAID-Clean Cities Blue Oceans	Renerio Acosta	Clean Cities Blue Oceans, Regional Director, Asia Pacific
USAID-Clean Cities Blue Oceans	Eric Desroberts	Global Engagement Director
World Bank Group	Delphine Arri	Senior environmental Engineer, East Asia & Pacific

A summary of the stakeholder analysis will be prepared as shown in the table below. We acknowledge for a project spanning the Pacific Region that stakeholdership is diverse and heterogeneous. We anticipate varying degrees of interest, impact and influence throughout stakeholder groups and thus will consider the level at which individual stakeholders might be impacted.

**Table 36 Stakeholder Analysis**

Stakeholder Group	Stakeholder Name	Interest	Influence	Probability	Action to maximise support	Reaction to minimise disruption
Local Community						
Interest Groups						
Business and Industry						
Government						
Donors						
Other Agencies						

Note: **Interest** states whether it is positive or negative, and whether it is financial, technical, environmental, organizational, commercial, political, etc. **Influence/impact** sets out the possible effects of stakeholder interference, which may be helpful or disruptive. **Probability** can only be completed following a preliminary risk analysis based on experience and other techniques. **Action** relates to positive stakeholders and lists the best ways to generate support, such as maintaining good personal relations, invitations to certain meetings and updated information. **Reaction** sets out the tactics to dispel unfounded fears, malicious rumours and physical disruptions.

Areas of interest (or concern) identified during consultation. Virtual workshops and interviews will identify key risk areas/concerns for stakeholder management. Below are broad expectations based on previous experience and engagement. Specific and contextualised areas will be determined through the proposed consultations.

**Table 37 Stakeholder Interest and Concerns**

<b>Stakeholder Group</b>	<b>Area of Interest</b>	<b>Level of influence</b>
Local Community	<p>E.g., Social impacts, including:</p> <ul style="list-style-type: none"> <li>- Noise and smell</li> <li>- Vibration</li> <li>- Visual amenity</li> <li>- Health impacts</li> <li>- Social stigma</li> </ul> <p>Environment issues, including:</p> <ul style="list-style-type: none"> <li>- Adherence to standards</li> <li>- Land and marine management.</li> </ul> <p>Economic issues, including:</p> <ul style="list-style-type: none"> <li>- Employment</li> <li>- Improved infrastructure</li> </ul> <p>Engagement and trust, including:</p> <ul style="list-style-type: none"> <li>- Regularity and transparency of information</li> <li>- Commitment to timeframes</li> </ul>	E.g., Medium
Interest Groups	<p>E.g., Social impacts, including</p> <ul style="list-style-type: none"> <li>- Noise and smell</li> <li>- Safety</li> <li>- Visual amenity</li> <li>- Health impacts</li> <li>- Social stigma</li> </ul> <p>Economic issues, including:</p> <ul style="list-style-type: none"> <li>- Equal opportunity employment (Women, Youth, PWD)</li> </ul> <p>Environment issues, including:</p> <ul style="list-style-type: none"> <li>- Adherence to standards</li> <li>- Land and marine management.</li> </ul>	E.g., Medium
Business and Industry	<p>E.g., Economic issues, including:</p> <ul style="list-style-type: none"> <li>- Employment</li> <li>- Additional revenue streams</li> </ul>	E.g., High

	<ul style="list-style-type: none"> <li>- Improved infrastructure</li> <li>- Sustainable technologies (serviceable)</li> <li>- Marketability</li> </ul>	
Government	<p>E.g., Social impacts, including:</p> <ul style="list-style-type: none"> <li>- Noise and smell</li> <li>- Vibration</li> <li>- Visual amenity</li> <li>- Health impacts</li> <li>- Social stigma</li> </ul> <p>Environment issues, including:</p> <ul style="list-style-type: none"> <li>- Adherence to standards</li> <li>- Land and marine management.</li> </ul> <p>Economic issues, including:</p> <ul style="list-style-type: none"> <li>- Employment</li> <li>- Improved infrastructure</li> </ul>	E.g., Medium

## Draft interview questions for semi-structured group consultations

### 1. Overview

- 1.1. Provide an overview of the current state of plastic waste management in your Pacific Island Country (PIC) or community?

### 2. Waste Generation

- 2.1. How would you describe the current levels of plastic waste generation in your PIC or community?
- 2.2. Are there specific sources or industries that contribute significantly to plastic waste in your region?

### 3. Waste Collection

- 3.1. What methods are currently employed for the collection of plastic waste in your PIC or community?
- 3.2. How effective are these collection methods, and are there any challenges associated with them?

### 4. Waste Processing Technologies

- 4.1. Can you share insights into the existing technologies used for processing plastic waste in your region?
- 4.2. Are there any innovative or unique approaches that have been implemented successfully?

### 5. Usable Commodities

- 5.1. What types of usable commodities are currently produced from processed plastic waste in your PIC or community?
- 5.2. How are these commodities utilised or integrated into local economies?

### 6. Barriers and Challenges

- 6.1. Are there any specific challenges or barriers hindering the efficient processing of plastic waste in your region?
- 6.2. How do economic, social, or environmental factors impact the adoption of plastic waste processing technologies?

### 7. Opportunities for Improvement

- 7.1. In your opinion, where do you see opportunities for improvement in plastic waste processing within your PIC or community?
- 7.2. Are there specific areas where external support or collaboration could enhance plastic waste management practices?

### 8. Community Engagement

- 8.1. How engaged is the local community in plastic waste management efforts, and what initiatives have been successful in raising awareness or encouraging participation?

### 9. Regulatory Environment

9.1. What is the regulatory framework surrounding plastic waste management in your PIC, and how does it influence current practices?

9.2. Are there any regulatory changes or updates that would positively impact plastic waste processing?

**10. Future Outlook**

10.1. Looking ahead, what are your expectations or aspirations for the future of plastic waste management in your region?

10.2. Are there any upcoming projects or initiatives aimed at advancing plastic waste processing capabilities that you know about?

**11. Knowledge Transfer and Collaboration**

11.1. How do information and knowledge about successful plastic waste processing initiatives get shared within the PICs or across Pacific Island Countries?

11.2. Are there opportunities for collaboration or knowledge exchange between PICs to enhance plastic waste management practices?

# Multi Criteria Analysis

# B

Methodology

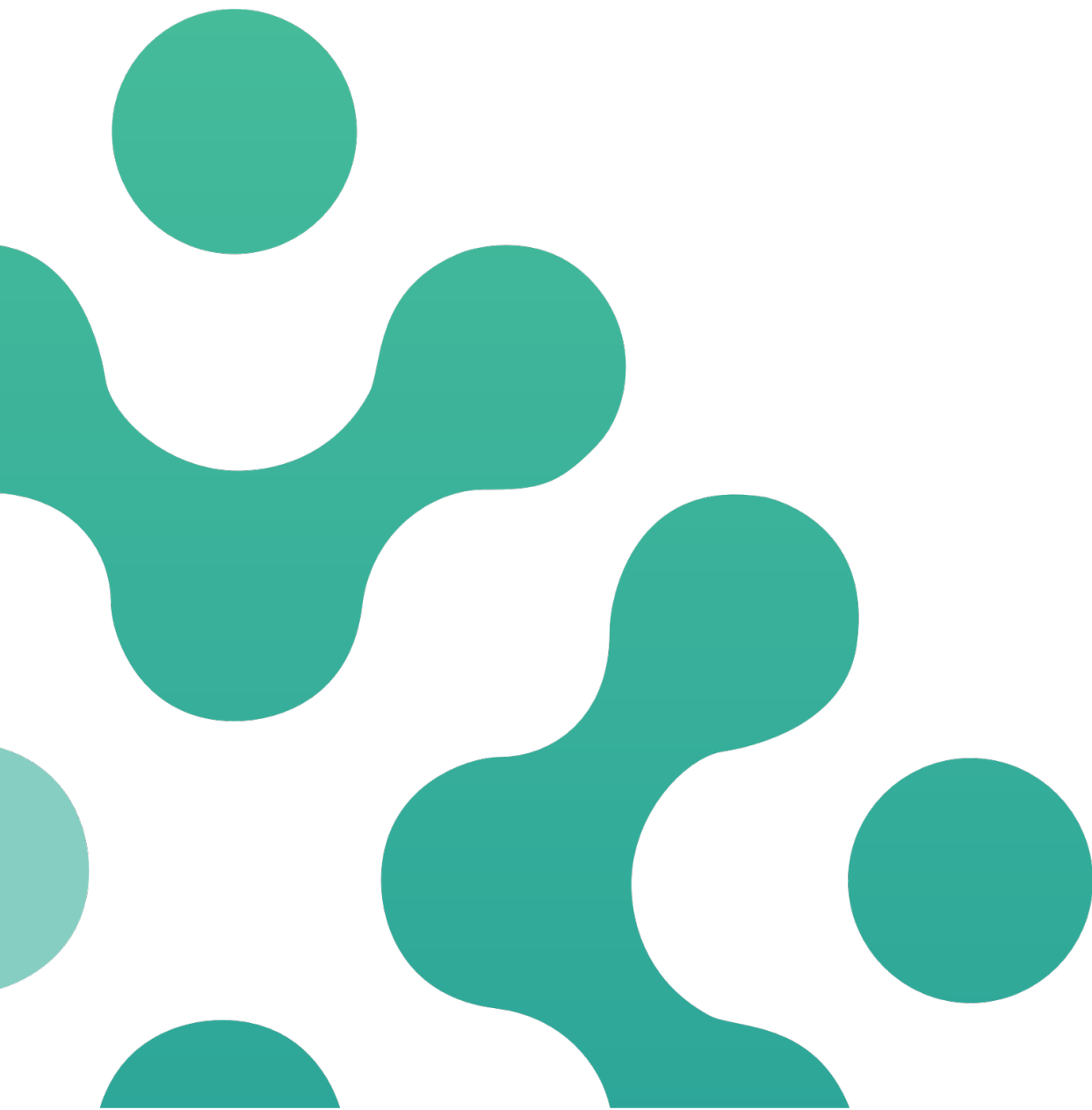



# MCA Method

This approach prioritises existing mechanical recycling technologies for plastic waste streams. The MCA aims to address multiple objectives (Supply and Demand, Technical, Human Resources, and Sustainability).

This MCA structure will be comprised of:

- **Objectives** describe the higher-level overarching priorities of the report.
- **Criteria** describe the desired outcomes or indicators by which the objectives will be measured.
- **Measures** connect the underlying evidence (quantitative) or judgements (qualitative) to the scores.
- **Score/Utility** is the assessment of an option’s relative performance against a measure.
- **Weight** is the assigned to indicate relative importance.

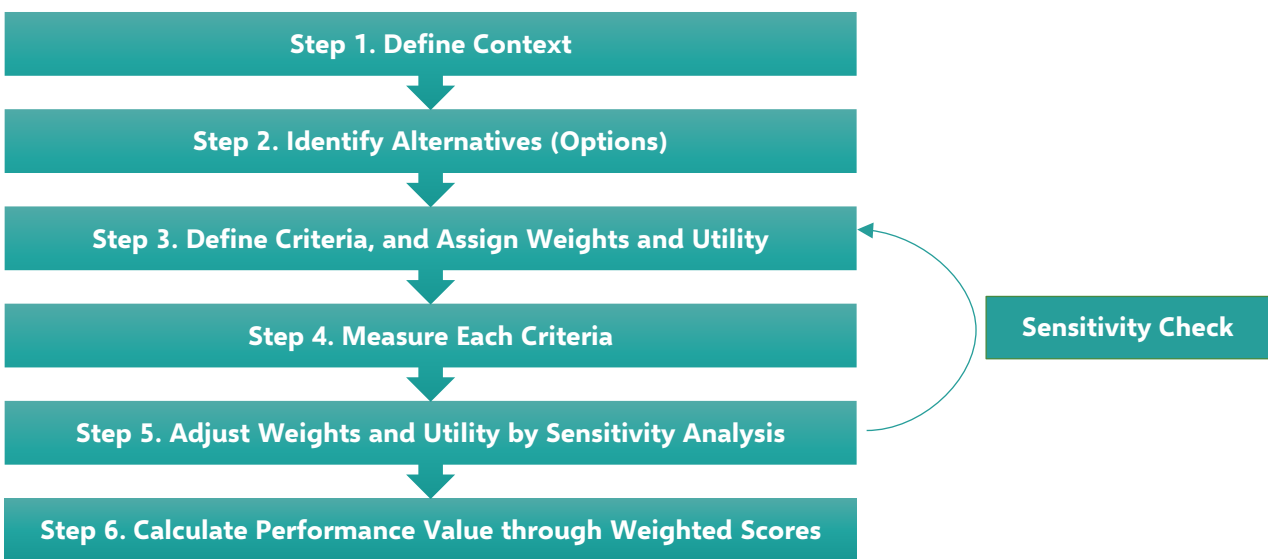

Figure 17 MCA Formation Process

The formation process of this MCA is outlined in Figure 17. Through this analysis, the weights and utility may be adjusted to best reflect the specific dependencies and relativities between options and are therefore subject to change.

The MCA sets score ranges (1-5 Likert scale) determined by using direct rating and value function techniques, individually score options against criteria, multiplied by the weight for each objective, and sums scores to generate a performance value that is used to evaluate each option relative to another. The option with the highest final performance value is considered the “most suitable” technology. Figure 18 illustrates this process. The current approach can be found in Table 38, Table 39, and Table 40. This assessment is currently operating under an evenly weighted approach, however, with regards to the assignment of relative importance of **Objective** weighting, we ask SPREP to indicate their preferred weighting, as well as any additional inclusions or exclusion of criteria and their respective preferential weighting.

The MCA analysed 8 potential technology options against four objectives and criteria (Table 38: Even-Weighting Assignment for Objectives and Criteria). Based on this analysis, pelletisers, granulators and shredders were the highest ranked largely due to their scoring in the technical suitability assessment. These are all stage 1 technologies that produce feedstock materials for further use. If there is a desired for that

further use to be developed within or across PICs, pelletisers (or granulators) + extrusion moulders followed by pelletisers (or granulators) + injection moulders are the technology combinations that are recommended.

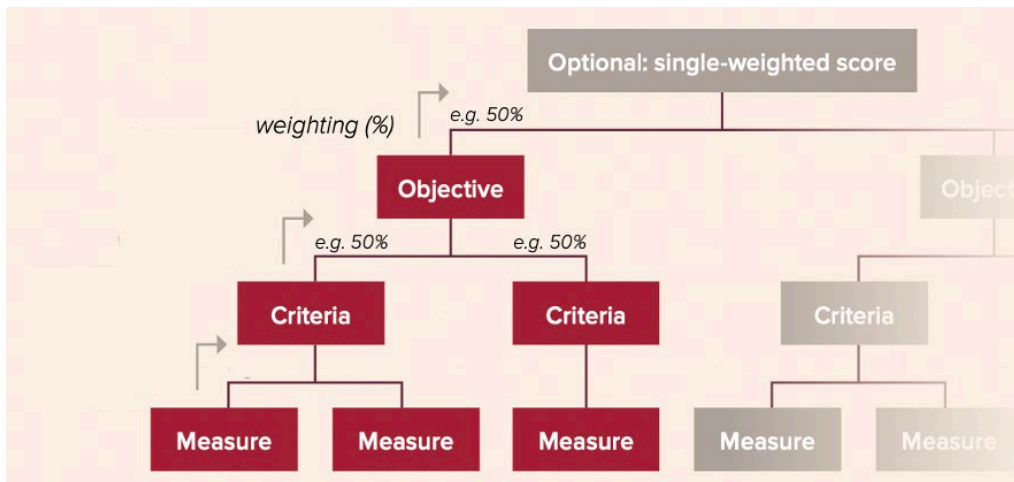

**Figure 18** Logical process of the proposed MCA approach with multiple objectives.

**Table 38: Even-Weighting Assignment for Objectives and Criteria**

O%	Objective	C%	Criteria
25%	Supply and Demand: To ensure there is sustainable supply and demand for the recycled commodity (domestic and internationally)	50%	Ensure sustainable supply of waste input materials
		50%	Ensure sustainable demand for recycled commodity
25%	Technical: To ensure options are selected with the most robust and sustainable technical capability for the processing of recyclable plastic materials in the Pacific region.	20%	Enhance the scale of technology for improved efficiency
		20%	Select technology that efficiently handles co-mingled plastics
		20%	Optimise site layout and design for operational sustainability
		20%	Optimise suitability for PICs use
		20%	Optimise labour inputs for increased productivity
25%	Human Resources: To ensure technologies have with the greatest positive social outcomes/impacts.	33%	Enhance capacity through skills development and targeted training programs
		33%	Simplify and streamline start up time requirements
		33%	Promote GEDSI principles throughout all aspects of the design
25%	Sustainability: To drive the adoption of context specific technological solutions with long-term resilience.	50%	Minimise external impacts associated with the technology
		50%	Optimise energy and water sustainable sourcing

**Table 39 Criteria and Measures**

CRITERIA	M%	Measures
Ensure sustainable supply of waste input materials	100%	Percentage of target waste stream it can address (throughput/total volume).
Ensure sustainable demand for recycled commodity	100%	Demand for product it can produce
Enhance the scale of technology for improved efficiency.	50%	Range of plastic products it can produce or can be produced from its output.
	50%	Volume of waste stream it targets
Select technology that efficiently handles a variety of plastic wastes	100%	Sensitivity to input quality
Optimise site layout and design for operational sustainability.	50%	Operations site size
	50%	Design complexity
Optimise suitability for PICs use.	50%	Prevalence of machinery in similar contexts
	50%	Repairability of technology
Optimise labour inputs for increased productivity	100%	Degree of Labour-intensive processes
Enhance capacity through skills development and targeted training programs	100%	Skill level required to operate and maintain technology
Promote GEDSI principles throughout all aspects of the design	100%	Technology use (e.g., Physical) accommodates gender, age, disabilities, cultural, and language differences.
Minimise external impacts associated with the technology	100%	Chemical Usage
Optimise energy and water sustainable sourcing.	50%	Water source
	50%	Energy source

**Table 40 Measures and assessment scoring sheet.**

Measures	Method	Score				
		1	2	3	4	5
Percentage of target waste stream it can address (throughput/total volume).	Quantitative	The technique manages a fraction of the target waste, perhaps around 5% or less.	The technique manages a small portion of the target waste, roughly 5% to 20%.	The technique manages a notable portion of the target waste, approximately 20% to 50%	The technique manages a substantial portion of the target waste, roughly 50% to 80%	The technique manages a significant majority of the target waste, potentially exceeding 80%
Demand for product it can produce	Qualitative	No demand.	Low demand or hobbyist. While the market may be small, there is potential for growth through targeted marketing to enthusiasts or specific interest groups.	Moderate demand. Consumers appreciate the uniqueness or craftsmanship of the product. Strategic efforts to enhance product features or market visibility may further capitalise on this demand.	High demand (meets a functional need). Product is in demand across a broader consumer base. notable and consistent interest, and the technology or process has established itself as a reliable source.	Very high demand (fills an under supplied niche). Product is highly sought after, with excessive demand from a wide consumer base. The technology has likely achieved a prominent position in the market.
Range of plastic products it can produce or can be produced from its output.	Quantitative	Can produce only one specific type of product, with no flexibility for variations	Can produce a few types of plastic products, but the variety is quite restricted	Can produce a moderate variety of products, covering some but not all common types	Can produce a wide variety of products, covering most common types and some specialised ones	Can produce an extensive variety of plastic products, including almost all common and specialised types, demonstrating high flexibility and versatility
Volume of waste stream it targets	Qualitative	The technique's constraints or	The technique's constraints or limiting	The technique's constraints or limiting	The technique's constraints or limiting	The technique's constraints or limiting

Measures	Method	Score				
		1	2	3	4	5
		limiting factors require highly technical and advanced knowledge to improve efficiency. This suggests a high level of complexity, demanding specialised expertise for optimization	factors require moderate technical knowledge to enhance efficiency. While not as demanding as highly technical constraints, it still necessitates a good understanding of the technology involved	factors present a moderate level of complexity, requiring some technical knowledge for optimisation. It's manageable with standard expertise and resources	factors are relatively straightforward, requiring minimal technical knowledge for improvement. It's accessible to a broader range of practitioners without extensive specialised training	factors are not technical in nature, allowing for easy adjustment or optimisation without specialised knowledge. It's user-friendly and can be adapted by individuals with various backgrounds
Sensitivity to input quality	Qualitative	Highly Sensitive. The machine's performance is greatly impacted by even minor changes in input quality	Sensitive. The machine's performance is noticeably affected by variations in input quality	Neutral. The machine's performance is somewhat sensitive variations in input quality but can be managed out	Insensitive. The machine's performance is minimally affected by changes in input quality	Highly Insensitive. The machine's performance remains consistent regardless of variations in input quality
Operations site size	Qualitative	Requires extensive private land and unattainable	Requires large parcel of private land and is typically unattainable	Requires medium parcel of land and is attainable by some	Requires small parcel of land or is mobile and attainable by many	Requires minimal land or is highly mobile and attainable by most

Measures	Method	Score				
		1	2	3	4	5
Design complexity	Qualitative	High complexity. Requires many specialised trades.	Moderate-high complexity. Requires several specialised trades.	Moderate complexity. Requires 1-2 specialised trades.	Moderate-low complexity. Requires 1-2 handymen.	Low complexity. Does not require external assistance.
Prevalence of machinery in similar contexts	Qualitative	Does not exist in any PIC: There is no evidence or instance of machinery being used in similar contexts	Rarely exists: Machinery is almost never used in similar contexts, with very few isolated pilot cases	Occasionally exists: Machinery is sometimes used in similar contexts, but it is not common practice	Frequently exists: Machinery is often used in similar contexts, though it may not be universally adopted	Well established: Machinery is consistently and widely used in similar contexts in PICs
Repairability of technology	Qualitative	Highly complex and bespoke technology requiring specialist overseas repair. All parts are custom and cannot be purchased off the market.	Complex technology requiring specialist repair (on or off island). All or most parts need to be imported.	Somewhat complex and can be repaired by a skilled handyman. Some parts need to be imported.	Simple and can be repaired by a local handyman. Parts are readily available.	Simple and can be repaired without specific technical knowledge. Parts are readily available
Degree of Labour-intensive processes	Qualitative	Extreme intensive. Tasks demand maximum physical effort and extended periods of time. The work is	High intensity. Substantial physical effort is necessary, and tasks can be physically demanding. The time required is significant, and the work	Moderate intensity. Tasks involve a moderate amount of physical effort and time investment. Work may require sustained attention and	Moderate-low intensity. Some physical effort is involved, but it is not overly strenuous. The time required for completion is	Low intensity. Tasks require minimal physical effort and can be completed quickly. Little time investment is needed, and the work is

Measures	Method	Score				
		1	2	3	4	5
		strenuous, labour-intensive, and may require breaks to avoid exhaustion.	may be challenging and time-consuming.	focus, but it is manageable.	moderate, indicating a balanced level of labour.	relatively straightforward.
Skill level required to operate and maintain technology	Qualitative	High technical skill level required. Complex, requires ongoing self-learning.	Moderate-high technical skill level required. Requires annual retraining/learning.	Moderate technical skill level required. Requires occasional (alternate years) retraining/learning.	Moderate-low technical skill level required. Requires retraining/learning once or twice only.	Low technical skill level required. Retraining/learning is optional.
Chemical Usage	Qualitative	Excessive usage. The technology relies heavily on chemical usage, potentially posing a high environmental risk.	High usage. The technology or process involves a significant amount of chemical usage. Environmental concerns may arise.	Moderate usage. Chemicals are used within industry-standard practices. There is a balance between operational efficiency and environmental considerations, with measures in place for proper handling and disposal.	Limited usage. Chemicals are used in a controlled and limited manner. Efforts are made to minimise the environmental footprint, with strict adherence to safety and disposal regulations.	Minimal usage. The technology or process involves minimal or no use of additional chemicals.
Water source	Qualitative	Excessive impact. Technology heavily relies on water with high impact on water	High impact. Technology relies significantly on water	Moderate impact. Moderate amount of water with a focus on responsible sourcing in	Moderate to low impact. Water is used to some extent. Technology minimises water consumption	Minimal impact. Consumption is extremely low, and sourcing is managed

Measures	Method	Score				
		1	2	3	4	5
		resources, potentially leading to environmental degradation and community concerns.	and requires advanced conservation measures.	lieu of more efficient systems.	through efficient systems.	responsibly, minimising environmental impact.
Energy source	Qualitative	Excessive impact. Technology heavily relies on energy, potentially leading to environmental degradation and community concerns due to excessive energy consumption.	High impact. Technology has high energy needs and requires advanced conservation measures to minimise environmental impact.	Moderate impact. Moderate consumption with a focus on responsible sourcing in lieu of more efficient systems.	Moderate to low impact. Consumption is moderate. Compatible with renewable energy sources to contribute significantly to the technology's power needs.	Minimal impact. Consumption is low, and sourcing is from renewable or low-impact sources, aligning with sustainable practices.



ISBN 978-982-04-1365-8



9 789820 413658